

### **TYPE 1 – B-24D WITH ALL-GLAZED NOSE**

Type 1 as defined for this book includes all B-24s with the fully-glazed nose. In combat this was used only on D models of the B-24 and a few LB-30s present during the very early days of WWII. Domestically the glazed nose was used on B-24A, B, C, D, E and early G models. Modified Ds and all later models carried a nose turret. None of the D models used in the European and Caribbean Theatres carried a nose turret except for some Anti-Submarine units.

B-24Ds were manufactured by the Consolidated-Vultee Aircraft Corporation (Convair) (earlier Consolidated Aircraft Corporation (CAC)) in their San Diego, California, and Fort Worth, Texas, plants. There were only three Fort Worth (B-24D-CF) aircraft in the 380<sup>th</sup>. All the others were San Diego (B-24D-CO). Two of the CF aircraft were RCM (ferret) specialists on temporary duty with the 380<sup>th</sup>.

All of the initial deployment aircraft came overseas with glazed noses, i.e., Type 1. Seven were later modified by the Townsville Air Depot by adding turrets (Consolidated A6As) to become Type 2 while still in service with the 380<sup>th</sup>. Several others were also so modified after their period of service with the 380<sup>th</sup>. The others remained as Type 1 throughout their service until lost or salvaged.

All 380<sup>th</sup> aircraft were modified in theatre to remove the ball turret because of the excess weight involved. It was replaced by a pair of machine guns mounted on a Scarff ring in the same location.

## Consolidated B-24D

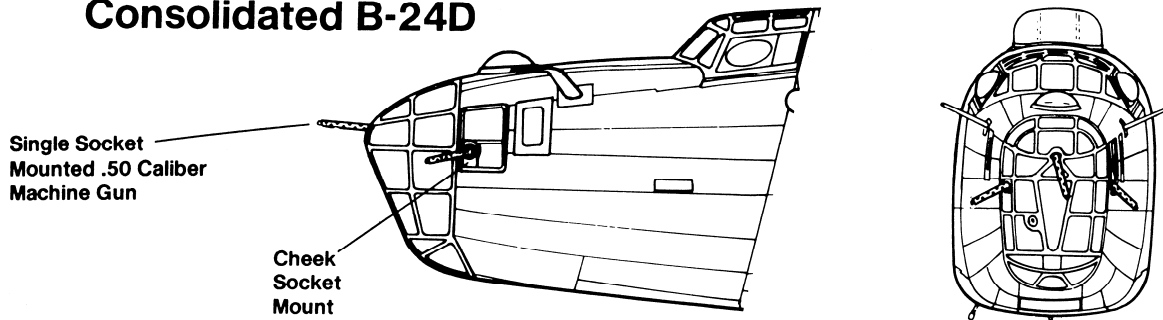

## Nose Armament

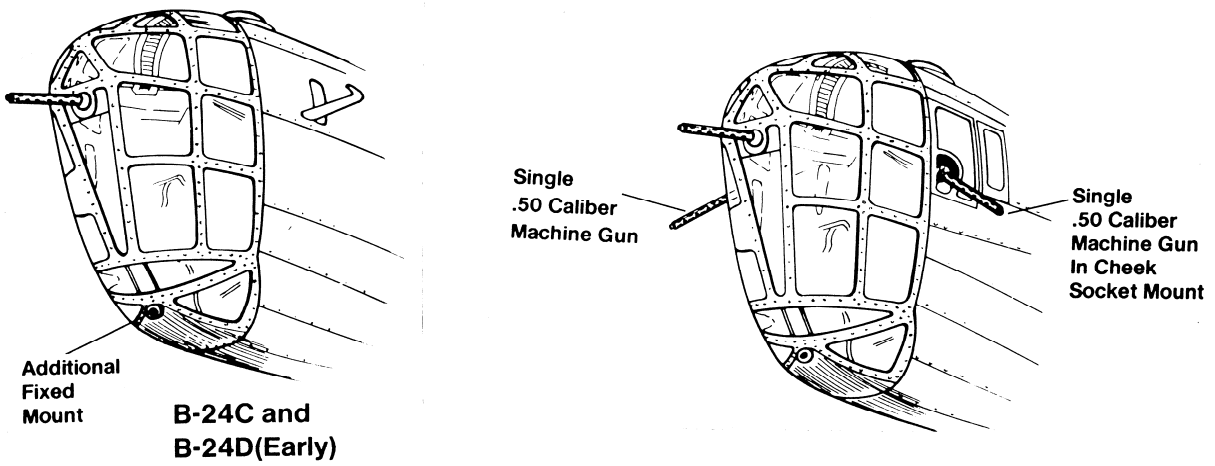

Source: *B-24 Liberator in Action*, Squadron/Signal Publications, Inc., Aircraft Number 80, 1987, pp. 16, 23 (modified).

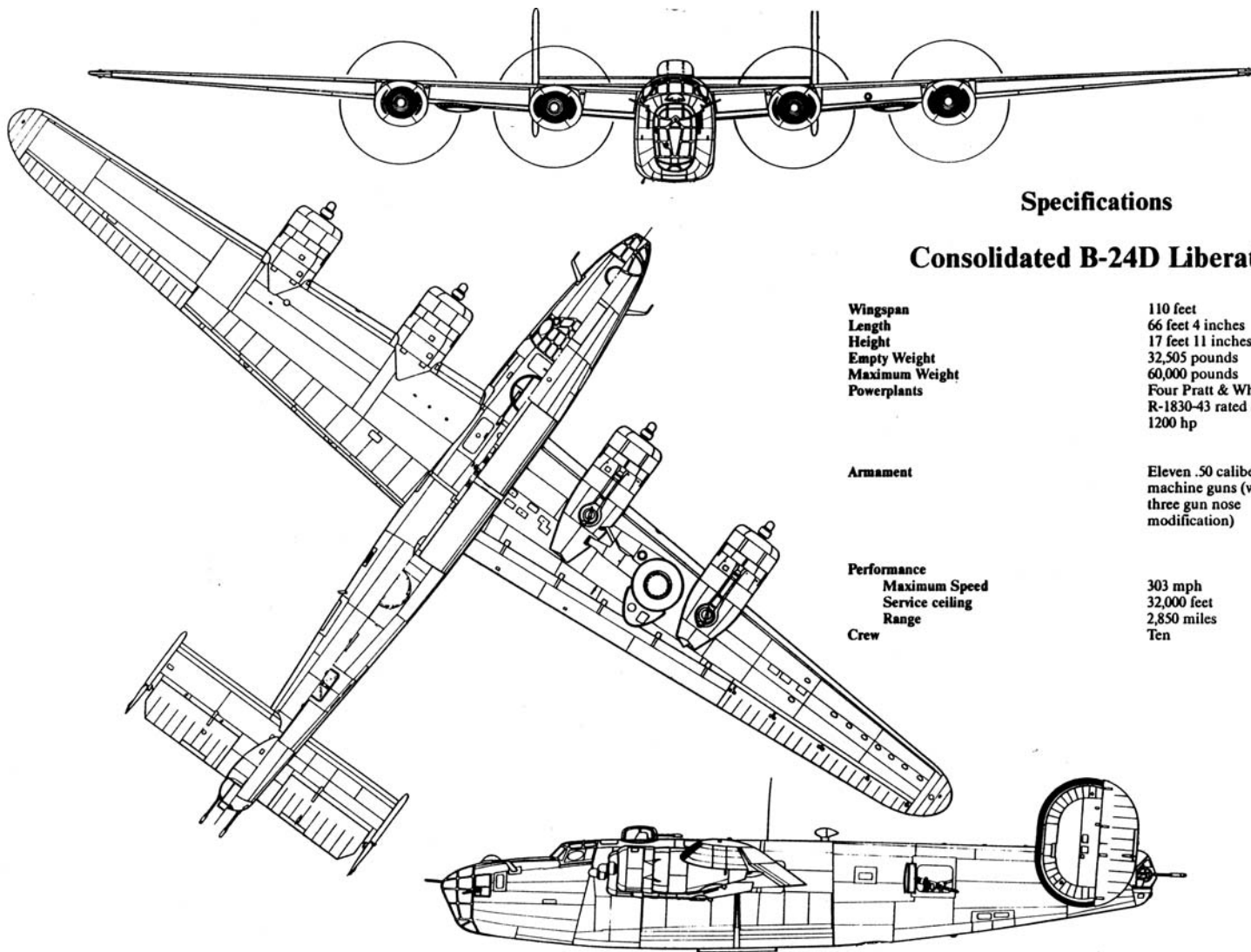

## Specifications

### Consolidated B-24D Liberator

<b>Wingspan</b>	110 feet
<b>Length</b>	66 feet 4 inches
<b>Height</b>	17 feet 11 inches
<b>Empty Weight</b>	32,505 pounds
<b>Maximum Weight</b>	60,000 pounds
<b>Powerplants</b>	Four Pratt & Whitney R-1830-43 rated at 1200 hp
<b>Armament</b>	Eleven .50 caliber machine guns (with three gun nose modification)
<b>Performance</b>	
<b>Maximum Speed</b>	303 mph
<b>Service ceiling</b>	32,000 feet
<b>Range</b>	2,850 miles
<b>Crew</b>	Ten

Source: *B-24 Liberator in Action*, Squadron/Signal Publications, Inc., Aircraft Number 80, 1987, pp. 16, 23 (modified).

**THESE FIRST TWO AIRCRAFT WERE REPLACEMENT AIRCRAFT, WHICH WERE OLDER THAN THE 380<sup>TH</sup>'S OWN ORIGINAL COMPLEMENT. THEY WERE PREVIOUSLY FLOWN BY OTHER GROUPS IN SOUTHWEST PACIFIC AREA.**

001	41-24248	ALLEY OOP
002	42-40351	BIG CHIEF COCKEYE

**STATISTICAL SUMMARY**  
**FATES OF OUR AIRCRAFT – AUSTRALIAN AND NEW GUINEA CAMPAIGN**  
**380<sup>TH</sup> BOMB GROUP (H)**

**OLDER REPLACEMENT PLANES**

#	AIRCRAFT	R	C	CA	MA	AM	ASM	A	AS	WWS	RAAF	OG	PI	NT	RUS
1	41-24248 ALLEY OOP							✓ 8/21/43						N	
2	42-40351 BIG CHIEF COCKEYE				✓ 7/5/44									✓	
	TOTALS				1			1						1	

*Legend:*

- R Destruction As Result of Enemy Air Raid
- C Loss of Aircraft in Enemy Territory Due Directly to Enemy Action
- CA Accident and/or Salvage As Result of Enemy Combat Damage (In Friendly Territory)
- MA Loss While on Mission While in Enemy Territory but Direct Enemy Action Not Involved
- A Accident in Friendly Territory Causing Complete Destruction of Aircraft – Not Combat Mission Related
- AM Same as A but Involved in Combat Mission
- AS Accident in Friendly Territory Resulting in Salvage of the Aircraft – Not Combat Mission Related
- ASM Same as AS but Involved in Combat Mission
- WWS Salvage of Aircraft as War Weary
- RAA Transfer of Aircraft to Royal Australian Air Force
- F
- OG Transfer of Aircraft to Other Groups
- PI Transfer to Philippines Islands for Continuation of War Service There
- NT Whether Nose Turret Installed
- RUS Returned to U.S. at End of War



**THE NEXT 38 AIRCRAFT WERE THE ORIGINAL COMPLEMENT FLOWN  
OVERSEAS BY 380<sup>TH</sup> BOMB GROUP PERSONNEL**

**Listed by Serial Number:**

003	42-40369	SHADY LADY
004	42-40387	BEAUTIFUL BETSY
005	42-40393	BLACK MAGIC
006	42-40485	“FYRTLE MYRTLE”
007	42-40486	DIS-GUSTED
008	42-40489	MISS GIVING
009	42-40491	POOCHIE
010	42-40492	MISS MARY
011	42-40493	LITTLE EVE
012	42-40495	DAUNTLESS “DOTTIE”
013	42-40496	“JUAREZ WHISTLE”
014	42-40497	OLE 8 BALL / HOMMA HOMMA KID
015	42-40500	CARELESS
016	42-40502	PEGGY / HELL’S ANGEL
017	42-40504	GUS’S BUS
018	42-40505	MR FIVE BY FIVE
019	42-40507	ESMERALDA II
020	42-40508	80 DAYS MAJOR
021	42-40509	NOTHING SACRED
022	42-40510	JUNGLE QUEEN II
023	42-40511	“LADY JEANNE”
024	42-40512	SHE ‘ASTA
025	42-40513	SNAFU
026	42-40514	LUCKY
027	42-40515	“SOOPER DROOPER”
028	42-40516	“ROBBIE L”
029	42-40517	KATHY
030	42-40518	PUG / GOLDEN GATOR
031	42-40519	(UNKNOWN)
032	42-40521	THE GOLDEN GOOSE
033	42-40522	DELIVERER
034	42-40524	THE RED ASS
035	42-40525	TOUGHY
036	42-40526	PRINCE VALIANT / PUG (II)
037	42-40527	THE LEILA BELLE
038	42-40528	DAUNTLESS DABBIE
039	42-40532	“LITTLE JOE”
040	42-40534	THE ONE

**Listed by Name:**

031	42-40519	(UNKNOWN)
020	42-40508	80 DAYS MAJOR
004	42-40387	BEAUTIFUL BETSY
005	42-40393	BLACK MAGIC
015	42-40500	CARELESS
038	42-40528	DAUNTLESS DABBIE
012	42-40495	DAUNTLESS "DOTTIE"
033	42-40522	DELIVERER
007	42-40486	DIS-GUSTED
019	42-40507	ESMERALDA II
006	42-40485	"FYRTLE MYRTLE"
017	42-40504	GUS'S BUS
013	42-40496	"JUAREZ WHISTLE"
022	42-40510	JUNGLE QUEEN II
029	42-40517	KATHY
023	42-40511	"LADY JEANNE"
011	42-40493	LITTLE EVE
039	42-40532	"LITTLE JOE"
026	42-40514	LUCKY
008	42-40489	MISS GIVING
010	42-40492	MISS MARY
018	42-40505	MR FIVE BY FIVE
021	42-40509	NOTHING SACRED
014	42-40497	OLE 8 BALL / HOMMA HOMMA KID
016	42-40502	PEGGY / HELL'S ANGEL
009	42-40491	POOCHIE
036	42-40526	PRINCE VALIANT / PUG (II)
030	42-40518	PUG / GOLDEN GATOR
028	42-40516	"ROBBIE L"
003	42-40369	SHADY LADY
024	42-40512	SHE 'ASTA
025	42-40513	SNAFU
027	42-40515	"SOOPER DROOPER"
032	42-40521	THE GOLDEN GOOSE
037	42-40527	THE LEILA BELLE
040	42-40534	THE ONE
034	42-40524	THE RED ASS
035	42-40525	TOUGHY



**STATISTICAL SUMMARY  
FATES OF OUR AIRCRAFT – EAST INDIAN AND NEW GUINEA CAMPAIGN  
380<sup>TH</sup> BOMB GROUP (H)**

**ORIGINAL DEPLOYMENT PLANES**

#	AIRCRAFT	R	C	CA	MA	AM	ASM	A	AS	WWS	RAAF	OG	PI	NT	RUS
3	42-40369 SHADY LADY						✓ 8/14/43							✓	
4	42-40387 BEAUTIFUL BETSY							✓ 2/26/45						N	
5	42-40393 BLACK MAGIC	✓ 6/30/43												N	
6	42-40485 “FYRTLE MYRTLE”		✓ 10/26/43											✓	
7	42-40486 DIS-GUSTED	✓ 6/30/43												N	
8	42-40489 MISS GIVING										✓ 12/13/43			N	
9	42-40491 POOCHIE							✓ 7/31/43						N	
10	42-40492 MISS MARY		✓ 7/10/43											N	
11	42-40493 LITTLE EVE											✓ 8/1/43		N	
12	42-40495 DAUNTLESS “DOTTIE”												✓ 3/45	N	
13	42-40496 “JUAREZ WHISTLE”								✓ 2/1/44					✓ 7/43	
14	42-40497 HOMMA HOMMA KID	✓ 7/6/43												N	
TOTALS THIS PAGE		3	2				1	2	1		1	1	1	3	
BROUGHT FORWARD															
TOTALS, OVERALL		3	2				1	2	1		1	1	1	3	

**STATISTICAL SUMMARY  
FATES OF OUR AIRCRAFT – EAST INDIAN AND NEW GUINEA CAMPAIGN  
380<sup>TH</sup> BOMB GROUP (H)**

**ORIGINAL DEPLOYMENT PLANES (continued)**

#	AIRCRAFT	R	C	CA	MA	AM	ASM	A	AS	WWS	RAAF	OG	PI	NT	RUS
15	42-40500 CARELESS		✓ 6/11/43											N	
16	42-40502 HELL'S ANGEL								✓ 6/30/43					N	
17	42-40504 GUS'S BUS								✓ 10/20/43					N	
18	42-40505 MR FIVE BY FIVE											✓ 12/11/43		N	
19	42-40507 ESMERALDA II		✓ 7/10/43											N	
20	42-40508 80 DAYS MAJOR								✓ 9/23/43					N	
21	42-40509 NOTHING SACRED			✓ 9/21/43										N	
22	42-40510 JUNGLE QUEEN II									✓ 12/13/43				✓	
23	42-40511 "LADY JEANNE"									✓ 12/13/43				N	
24	42-40512 SHE'ASTA										✓ 12/13/43			N	
25	42-40513 SNAFU								✓ 9/15/43					N	
26	42-40514 LUCKY										✓ 10/18/43			N	
TOTALS THIS PAGE			2	1					4	2	2	1		1	
BROUGHT FORWARD		3	2				1	2	1		1	1	1	3	
TOTALS, OVERALL		3	4	1			1	2	5	2	3	2	1	4	

**STATISTICAL SUMMARY  
FATES OF OUR AIRCRAFT – EAST INDIAN AND NEW GUINEA CAMPAIGN  
380<sup>TH</sup> BOMB GROUP (H)**

**ORIGINAL DEPLOYMENT PLANES (continued)**

#	AIRCRAFT	R	C	CA	MA	AM	ASM	A	AS	WWS	RAAF	OG	PI	NT	RUS
27	42-40515 "SOOPER DROOPER"											✓ 12/13/43		N	
28	42-40516 "ROBBIE L"								✓ 6/23/43					N	
29	42-40517 KATHY			✓ 6/15/43										N	
30	42-40518 PUB / GOLDEN GATOR		✓ 10/26/43											N	
31	42-40519 (UNKNOWN)							✓ 5/15/43						N	
32	42-40521 GOLDEN GOOSE									✓ 12/1/43				N	
33	42-40522 DELIVERER										✓ 12/13/43			N	
34	42-40524 THE RED ASS		✓ 9/11/43											N	
35	42-40525 TOUGHY											✓ 12/5/43		N	
36	42-40526 PRINCE VALIANT												✓ 3/45	✓	
37	42-40527 LEILA BELLE		✓ 6/11/43											N	
38	42-40528 DAUNTLESS DABBIE			✓ 6/15/43										N	
TOTALS THIS PAGE			3	2				1	1	1	1	2	1	1	
BROUGHT FORWARD		3	4	1			1	2	5	2	3	2	1	4	
TOTALS, OVERALL		3	7	3			1	3	6	3	4	4	2	5	

**STATISTICAL SUMMARY  
FATES OF OUR AIRCRAFT – EAST INDIAN AND NEW GUINEA CAMPAIGN  
380<sup>TH</sup> BOMB GROUP (H)**

**ORIGINAL DEPLOYMENT PLANES (continued)**

#	AIRCRAFT	R	C	CA	MA	AM	ASM	A	AS	WWS	RAAF	OG	PI	NT	RUS
39	42-40532 "LITTLE JOE"		✓ 9/21/43											✓ 5/43	
40	42-40534 THE ONE											✓ 101/43		✓ 5/43	
TOTALS THIS PAGE			1									1		2	
BROUGHT FORWARD		3	7	3			1	3	6	3	4	4	2	5	
TOTALS, OVERALL		3	8	3			1	3	6	3	4	5	2	7	

*Legend:*

- R Destruction As Result of Enemy Air Raid
- C Loss of Aircraft in Enemy Territory Due Directly to Enemy Action
- CA Accident and/or Salvage As Result of Enemy Combat Damage (In Friendly Territory)
- MA Loss While on Mission While in Enemy Territory but Direct Enemy Action Not Involved
- A Accident in Friendly Territory Causing Complete Destruction of Aircraft – Not Combat Mission Related
- AM Same as A but Involved in Combat Mission
- AS Accident in Friendly Territory Resulting in Salvage of the Aircraft – Not Combat Mission Related
- ASM Same as AS but Involved in Combat Mission
- WWS Salvage of Aircraft as War Weary
- RAA Transfer of Aircraft to Royal Australian Air Force
- F
- OG Transfer of Aircraft to Other Groups
- PI Transfer to Philippines Islands for Continuation of War Service There
- NT Whether Nose Turret Installed (Applies Only to Initial Deployment Aircraft) During 1943
- RUS Returned to U.S. at End of War

**PLANES KNOWN TO BE AT FENTON  
FROM MISSION REPORTS**

No.	Serial No.	FENTON MISSION # AND DATE								
			6/03	6/10	6/11	6/15	6/21	6/23	6/27	6/29
		26	29	34	35	37	39	42	43	44
003	42-40369 SHADY LADY			✓				✓		
004	42-40387 BEAUTIFUL BETSY	✓	✓		✓		✓	✓	✓	
005	42-40393 BLACK MAGIC		✓	Air Raid						
006	42-40485 "FYRTL MYRTLE"	Nose Turret Installation								
007	42-40486 DIS-GUSTED		✓	Air Raid						
008	42-40489 MISS GIVING				✓	✓	✓	✓		✓
009	42-40491 POOCHIE					✓	✓	✓		
010	42-40492 MISS MARY				✓			✓	✓	✓
011	42-40493 LITTLE EVE				✓		✓			
012	42-40495 DAUNTLESS "DOTTIE"				✓	✓		✓		
013	42-40496 "JUAREZ WHISTLE"				✓	✓	✓	✓		
014	42-40497 HOMMA HOMMA KID				✓			✓	✓	✓
015	42-40500 CARELESS				✓	Lost				
019	42-40507 ESMERALDA II				✓	✓	✓	✓	✓	
022	42-40510 JUNGLE QUEEN II				✓			✓	✓	
023	42-40511 "LADY JEANNE"				✓	✓	✓	✓		
024	42-40512 SHE' ASTA				✓					
025	42-40513 SNAFU				✓	✓	✓	✓	✓	
028	42-40516 "ROBBIE L"				✓	✓	✓	✓		

No.	Serial No.	FENTON MISSION # AND DATE								
			6/03	6/10	6/11	6/15	6/21	6/23	6/27	6/29
		26	29	34	35	37	39	42	43	44
031	42-40519 UNKNOWN	Lost Enroute								
032	42-40521 GOLDEN GOOSE				✓	✓	✓	✓		✓
034	42-40524 THE RED ASS				✓					
039	42-40532 "LITTLE JOE"	Nose Turret Installation								
040	42-40534 THE ONE	Nose Turret Installation								

**PROBABLE AIRCRAFT  
NEW GUINEA DEPLOYMENT I  
MAY – JUNE 1943**

<b>No.</b>	<b>Serial No.</b>	<b>Nose Art</b>	<b>Notes</b>
016	42-40502	HELL'S ANGEL	Take-off crash, 06/03/1943
017	42-40504	GUS'S BUS	
018	42-40505	MR FIVE BY FIVE	
020	42-40508	80 DAYS MAJOR	
021	42-40509	NOTHING SACRED	
026	42-40514	LUCKY	
027	42-40515	"SOOPER DROOPER"	
029	42-40517	KATHY	Mid-air collision, 06/15/1943
030	42-40418	PUG	
033	42-40522	DELIVERER	
035	42-40525	TOUGHY	
036	42-40526	PRINCE VALIANT	
037	42-40527	THE LEILA BELLE	Shot down, 06/11/1943
038	42-40528	DAUNTLESS DABBIE	Mid-air collision, 06/15/1943