

B-24 – M MODELS

TYPE 11 – FORD B-24 M-FO

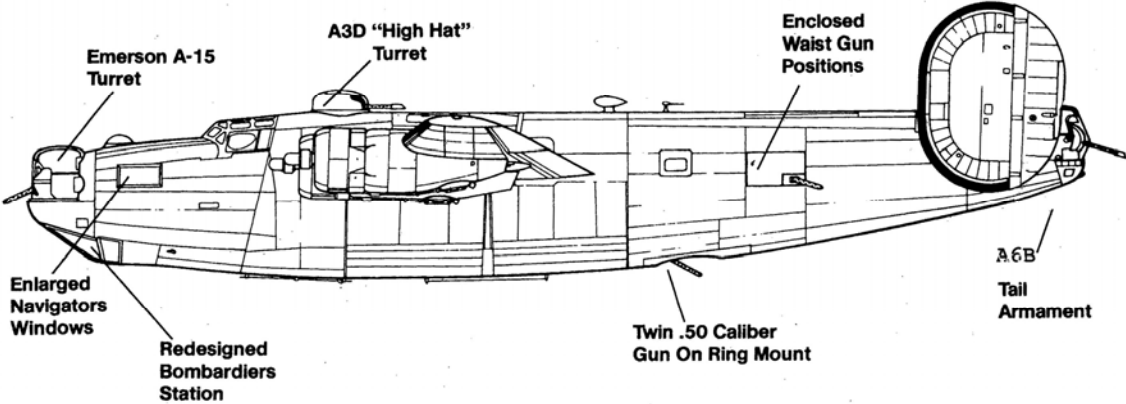

NOTE NAVIGATOR'S DRIFT METER BEHIND COPILOT'S POSITION (RIGHT SIDE OF FORD M MODELS) IN FOLLOWING PICTURES.

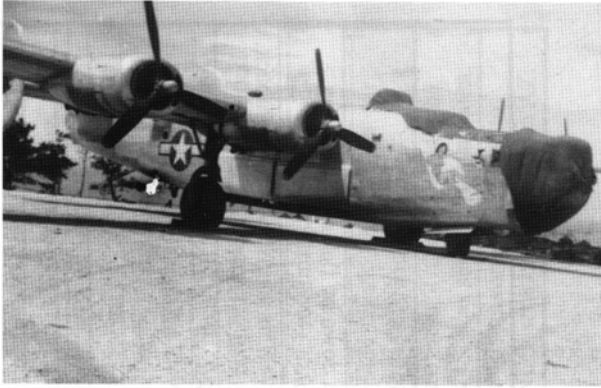

Source: Horton, *Best in the Southwest*, p. 462.

A 531st "M" carrying the last style of tail markings.
Robert Withom Collection

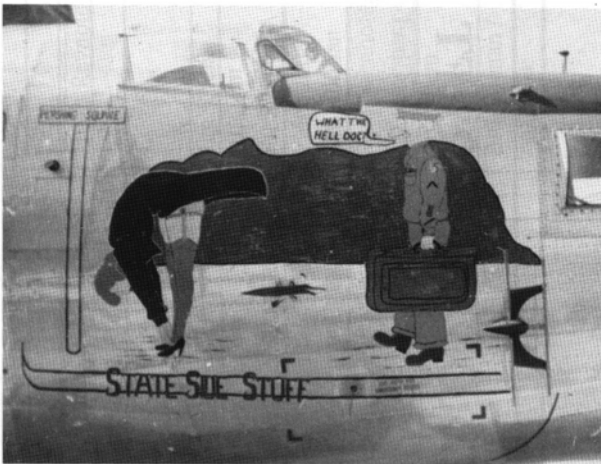

This "M" has artwork that says "Flying Circus" on the suit case. *Clarence Frankford Collection*



Known to be with the 531st. *Frank Wojnilko Collection*

**STATISTICAL SUMMARY
FATES OF OUR AIRCRAFT – PHILIPPINES CAMPAIGN
380TH BOMB GROUP (H)**

M-FO MODELS

#	AIRCRAFT	R	C	CA	MA	AM	ASM	A	AS	WWS	RAAF	OG	RUS	TOTAL
167	44-50390 BECOMIN' BACK		✓ 7/12/45											
168	44-50396 POM POM EXPRESS												✓ 10/45	
169	44-50405 TEN HIGH									✓ 02/46				
170	44-50456 (NONE)												✓ 10/45	
171	4-50459 (NONE)							✓ 9/8/45						
172	44-50602 DOUBLE TROUBLE												✓ 10/45	
173	44-50776 THE RAMBLIN' WRECK												✓ 10/45	
174	44-50782 (NONE)												✓ 11/45	
175	44-50794 (NONE)												✓ 10/45	
176	44-50811 PEACE OFFERING												✓ 10/45	
177	44-50894 LIBERTY BELLE									✓ 12/45				
178	44-50913 NOBODY'S DARLING									✓ 10/46				
TOTALS THIS PAGE			1					1		3			7	12
BROUGHT FORWARD														
TOTALS, OVERALL			1					1		3			7	12

**STATISTICAL SUMMARY
FATES OF OUR AIRCRAFT – PHILIPPINES CAMPAIGN
380TH BOMB GROUP (H)**

M-FO MODELS (continued)

#	AIRCRAFT	R	C	CA	MA	AM	ASM	A	AS	WWS	RAAF	OG	RUS	TOTAL
179	44-50927 (NONE)												✓ 10/45	
180	44-50941 "VIRGIN ABROAD"									✓ 10/45				
181	44-50971 (NONE)						✓ 6/17/45							
182	44-50977 (NONE)					✓ 6/21/45								
183	44-50988 (NONE)												✓ 10/45	
184	44-50997 (NONE)												✓ 10/45	
185	44-50998 CLARINE FROM ABILENE												✓ 10/45	
186	44-51005 BACHELOR'S BROTHEL												✓ 10/45	
187	44-51100 (NONE)												✓ 10/45	
TOTALS THIS PAGE						1	1			1			6	9
BROUGHT FORWARD			1					1		3			7	12
TOTALS, OVERALL			1			1	1	1		4			13	21

Legend:

R	Destruction As Result of Enemy Air Raid
C	Loss of Aircraft in Enemy Territory Due Directly to Enemy Action
CA	Accident and/or Salvage As Result of Enemy Combat Damage (In Friendly Territory)
MA	Loss While on Mission While in Enemy Territory but Direct Enemy Action Not Involved
A	Accident in Friendly Territory Causing Complete Destruction of Aircraft – Not Combat Mission Related
AM	Same as A but Involved in Combat Mission
AS	Accident in Friendly Territory Resulting in Salvage of the Aircraft – Not Combat Mission Related
ASM	Same as AS but Involved in Combat Mission
WWS	Salvage of Aircraft as War Weary
RAAF	Transfer of Aircraft to Royal Australian Air Force
OG	Transfer of Aircraft to Other Groups
RUS	Returned to U.S. at End of War