

B-24 – M MODELS

TYPE 12 – FORD B-24 M-FO

**B-24M-FO WITH REDESIGNED CANOPY/WINDSCREEN, OTHERWISE
SIMILAR TO OTHER LATE MODEL FORD PRODUCTION**

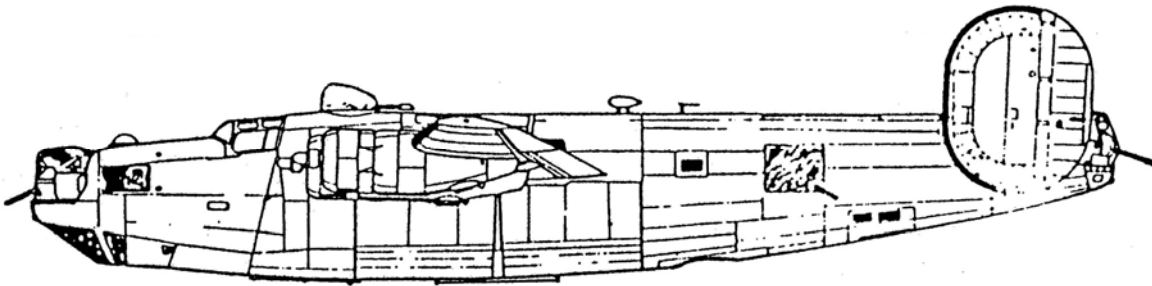

Willow Run made one last change to their B-24s with the introduction of the M-25-FO model; they made the front part of the canopy “V” shaped by taking out the flat center panel and the two triangular air vent windows. Aircraft with this modification had serials that began with 44-51252. Very few of these planes found their way into the 380th's inventory. Compare the two pilot's enclosures on the following two pages taken from the B-24M Parts Manual.

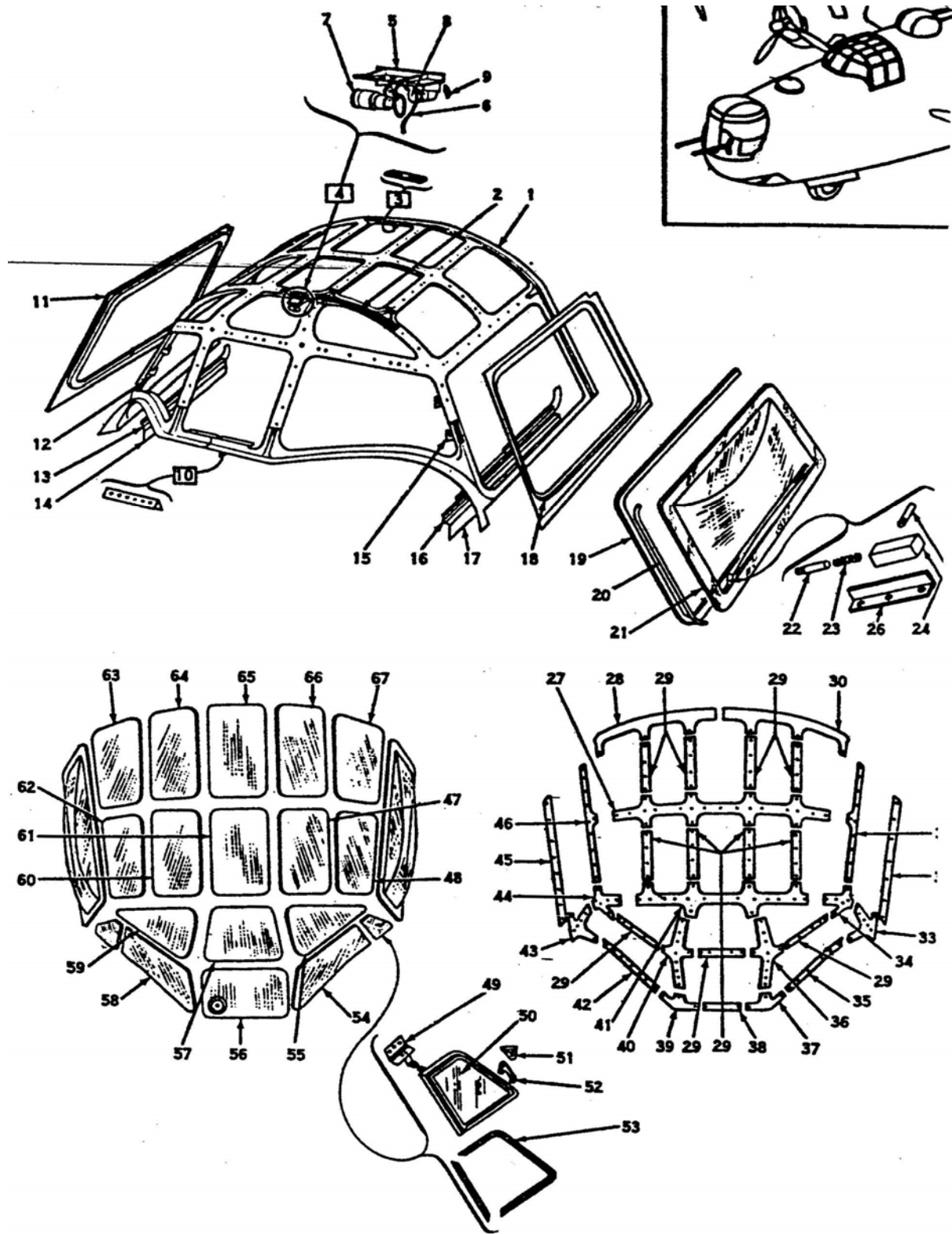

Source: Figure 10, B-24M Parts Manual.

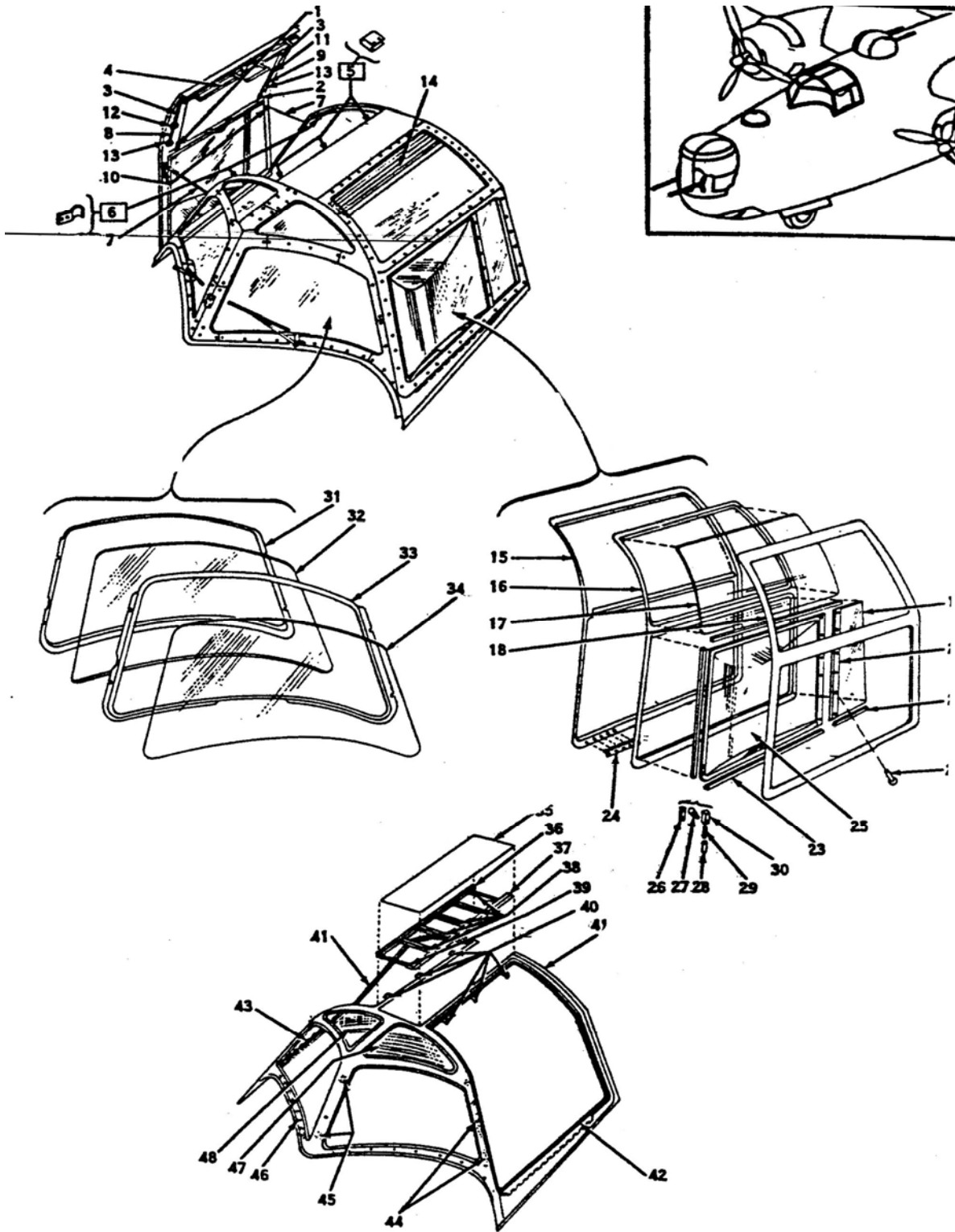

Source: Figure 11, B-24M Parts Manual.

**STATISTICAL SUMMARY
FATES OF OUR AIRCRAFT – PHILIPPINES CAMPAIGN
380TH BOMB GROUP (H)**

M – FO – 25 ADV

#	AIRCRAFT	R	C	CA	MA	AM	ASM	A	AS	WWS	RAAF	OG	RUS	TOTAL
188	44-51264 (NONE)												✓ 10/145	
189	44-51301 STATE SIDE STUFF												✓ 10/145	
190	44-51414 ATOMIC BLONDE												✓ 10/145	
TOTALS THIS PAGE													3	3
BROUGHT FORWARD														
TOTALS, OVERALL													3	3

Legend:

- R Destruction As Result of Enemy Air Raid
- C Loss of Aircraft in Enemy Territory Due Directly to Enemy Action
- CA Accident and/or Salvage As Result of Enemy Combat Damage (In Friendly Territory)
- MA Loss While on Mission While in Enemy Territory but Direct Enemy Action Not Involved
- A Accident in Friendly Territory Causing Complete Destruction of Aircraft – Not Combat Mission Related
- AM Same as A but Involved in Combat Mission
- AS Accident in Friendly Territory Resulting in Salvage of the Aircraft – Not Combat Mission Related
- ASM Same as AS but Involved in Combat Mission
- WWS Salvage of Aircraft as War Weary
- RAAF Transfer of Aircraft to Royal Australian Air Force
- OG Transfer of Aircraft to Other Groups
- RUS Returned to U.S. at End of War

**STATISTICAL SUMMARY
FATES OF OUR AIRCRAFT – PHILIPPINES CAMPAIGN
380TH BOMB GROUP (H)**

AIRCRAFT WITHOUT A COMBAT HISTORY

#	AIRCRAFT	R	C	CA	MA	AM	ASM	A	AS	WWS	RAAF	OG	RUS	TOTAL
191	44-41874 (NONE)												✓ 10/45	
192	44-42264 (NONE)												✓ 10/45	
193	44-42314 (NONE)												✓ 10/45	
194	44-42389 (NONE)												✓ 10/45	
195	44-42416 (NONE)												✓ 10/45	
196	44-42442 (NONE)									✓ 10/45				
197	44-50458 (NONE)									✓ 09/45				
198	44-51526 (NONE)												✓ 10/45	
199	44-51872 (NONE)												✓ 10/45	
TOTALS THIS PAGE										2			7	9
BROUGHT FORWARD														
TOTALS, OVERALL										2			7	9

Legend:

R	Destruction As Result of Enemy Air Raid
C	Loss of Aircraft in Enemy Territory Due Directly to Enemy Action
CA	Accident and/or Salvage As Result of Enemy Combat Damage (In Friendly Territory)
MA	Loss While on Mission While in Enemy Territory but Direct Enemy Action Not Involved
A	Accident in Friendly Territory Causing Complete Destruction of Aircraft – Not Combat Mission Related
AM	Same as A but Involved in Combat Mission
AS	Accident in Friendly Territory Resulting in Salvage of the Aircraft – Not Combat Mission Related
ASM	Same as AS but Involved in Combat Mission
WWS	Salvage of Aircraft as War Weary
RAAF	Transfer of Aircraft to Royal Australian Air Force
OG	Transfer of Aircraft to Other Groups
RUS	Returned to U.S. at End of War