

## B-24 – M MODELS

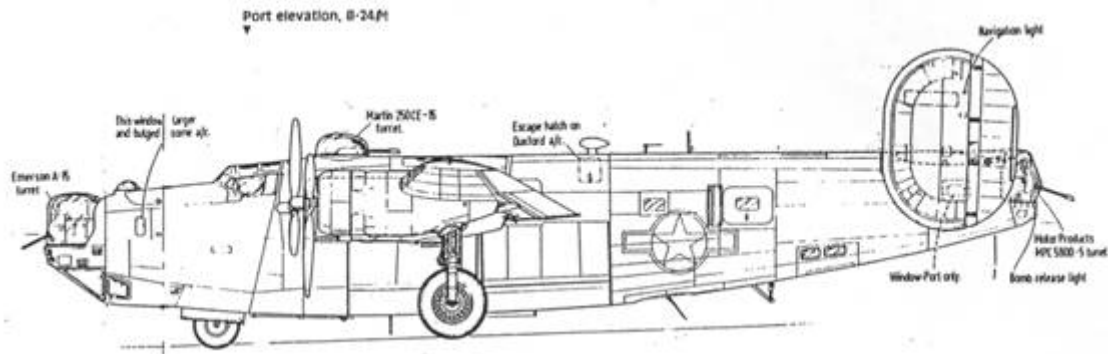

### TYPE 9 – CONSOLIDATED B-24 M-CO

The Consolidated B-24 M-CO differed in appearance from most B-24J-COs by having a larger and more bulged viewing window at the navigator's position in the nose. Compare [RANGY LIL](#) (an M) with [FLAK FLED FLAPPER](#) (a late J). The major difference was internal with more sophisticated radar and other electronic devices.



**RANGY LIL**

*Source: Horton, Best in the Southwest.*



Note the lack of external nose wheel doors indicating the ship has a hydraulically powered nose turret.  
*Jack West Collection*

### **FLAK FLED FLAPPER**

*Source: Horton, Best in the Southwest, p. 261.*

## M-CO RADARS

| No. | Serial No. | Nose Art              | Radar Type   |
|-----|------------|-----------------------|--|
| 140 | 44-41811   | "MISSOURI MISS"       | Single Rod Out                                     |
| 141 | 44-41849   | (NONE)                | Unknown  |
| 142 | 44-41867   | RANGY LIL             | Single Rod (Plus Single Rod Yogi Behind Astrodome) |
| 143 | 44-41875   | NET RESULTS           | Single Rod (Plus Yogi Behind Astrodome)            |
| 144 | 44-41876   | "LUCKY STRIKE"        | Single Rod (Plus Yogi Behind Astrodome)            |
| 145 | 44-42201   | BREADLINE IN '49      | Astrodome Yogi Only                                |
| 146 | 44-42214   | QUEEN OF THE STRIP    | Astrodome Yogi Only                                |
| 147 | 44-42242   | (NONE)                | Unknown  |
| 148 | 44-42244   | "DEANNA'S DREAMBOAT"  | Astrodome Yogi Only                                |
| 149 | 44-42248   | MY DEVOTION           | Astrodome Yogi Only                                |
| 150 | 44-42250   | NOCTURNAL MISSION     | Unknown  |
| 151 | 44-42263   | LUVABLASS             | Astrodome Yogi Only                                |
| 152 | 44-42323   | LIQUIDATOR            | Astrodome Yogi Only                                |
| 153 | 44-42329   | (NONE)                | Unknown  |
| 154 | 44-42331   | MOONLIGHT MAID        | Single Rod, Yogi on Side of Plane                  |
| 155 | 44-42351   | NANCY                 | Unknown  |
| 156 | 44-42352   | (NONE)                | Unknown  |
| 157 | 44-42378   | A WING AN' 10 PRAYERS | Single Rod, Yogi Behind Astrodome                  |
| 158 | 44-42381   | MISS ELISE            | Unknown  |
| 159 | 44-42397   | (NONE)                | Unknown  |
| 160 | 44-42412   | FREE FOR ALL!!!       | Unknown  |
| 161 | 44-42467   | (NONE)                | Unknown  |
| 162 | 44-49471   | (NONE)                | Unknown  |
| 191 | 44-41874   | (NONE)                | Unknown  |
| 192 | 44-42264   | (NONE)                | Unknown  |
| 193 | 44-42314   | (NONE)                | Unknown  |
| 194 | 44-42389   | (NONE)                | Unknown  |
| 195 | 44-42416   | (NONE)                | Unknown  |
| 196 | 44-42442   | (NONE)                | Unknown  |
| 197 | 44-50458   | (NONE)                | Unknown  |
| 198 | 44-51526   | (NONE)                | Unknown  |
| 199 | 44-51872   | (NONE)                | Unknown  |

**STATISTICAL SUMMARY  
FATES OF OUR AIRCRAFT – PHILIPPINES CAMPAIGN  
380<sup>TH</sup> BOMB GROUP (H)**

**M - CO MODELS**

| #                | AIRCRAFT                            | R | C | CA                | MA | AM | ASM | A | AS         | WWS | RAAF | OG | RUS        | TOTAL |
|------------------|-------------------------------------|---|---|-------------------|----|----|-----|---|------------|-----|------|----|------------|-------|
| 140              | 44-41811<br>"MISSOURI MISS"         |   |   |                   |    |    |     |   |            |     |      |    | ✓<br>10/45 |       |
| 141              | 44-41849<br>(NONE)                  |   |   |                   |    |    |     |   |            |     |      |    | ✓<br>10/45 |       |
| 142              | 44-41867<br>RANGY LIL               |   |   |                   |    |    |     |   |            |     |      |    | ✓<br>10/45 |       |
| 143              | 44-41875<br>NET RESULTS             |   |   |                   |    |    |     |   |            |     |      |    | ✓<br>10/45 |       |
| 144              | 44-41876<br>"LUCKY STRIKE"          |   |   |                   |    |    |     |   |            |     |      |    | ✓<br>10/45 |       |
| 145              | 44-42201<br>BREADLINE IN '49        |   |   |                   |    |    |     |   | ✓<br>08/45 |     |      |    |            |       |
| 146              | 44-42214<br>"QUEEN OF THE STRIP"    |   |   |                   |    |    |     |   |            |     |      |    | ✓<br>10/45 |       |
| 147              | 44-42242<br>(NONE)                  |   |   | ✓<br>04/15/<br>45 |    |    |     |   |            |     |      |    |            |       |
| 148              | 44-42244<br>"DEANNA'S<br>DREAMBOAT" |   |   |                   |    |    |     |   |            |     |      |    | ✓<br>10/45 |       |
| 149              | 44-42248<br>MY DEVOTION             |   |   |                   |    |    |     |   |            |     |      |    | ✓<br>10/45 |       |
| 150              | 44-42250<br>NOCTURNAL MISSION       |   |   |                   |    |    |     |   |            |     |      |    | ✓<br>10/45 |       |
| 151              | 44-42263<br>LUVABLASS               |   |   |                   |    |    |     |   |            |     |      |    | ✓<br>10/45 |       |
| TOTALS THIS PAGE |                                     |   |   | 1                 |    |    |     |   | 1          |     |      |    | 10         | 12    |
| BROUGHT FORWARD  |                                     |   |   |                   |    |    |     |   |            |     |      |    |            |       |
| TOTALS, OVERALL  |                                     |   |   | 1                 |    |    |     |   | 1          |     |      |    | 10         | 12    |

**STATISTICAL SUMMARY  
FATES OF OUR AIRCRAFT – PHILIPPINES CAMPAIGN  
380<sup>TH</sup> BOMB GROUP (H)**

**M - CO MODELS (Continued)**

| #                | AIRCRAFT                             | R | C                 | CA                | MA | AM | ASM | A | AS | WWS | RAAF | OG                | RUS        | TOTAL |
|------------------|--------------------------------------|---|-------------------|-------------------|----|----|-----|---|----|-----|------|-------------------|------------|-------|
| 152              | 44-42323<br>LIQUIDATOR               |   |                   |                   |    |    |     |   |    |     |      | ✓<br>10/45        |            |       |
| 153              | 44-42329<br>(NONE)                   |   | ✓<br>06/12/<br>45 |                   |    |    |     |   |    |     |      |                   |            |       |
| 154              | 44-42331<br>MOONLIGHT MAID           |   |                   |                   |    |    |     |   |    |     |      |                   | ✓<br>10/45 |       |
| 155              | 44-42351<br>NANCY                    |   |                   |                   |    |    |     |   |    |     |      | ✓<br>07/05/<br>45 |            |       |
| 156              | 44-42352<br>(NONE)                   |   | ✓<br>05/18/<br>45 |                   |    |    |     |   |    |     |      |                   |            |       |
| 157              | 44-42378<br>A WING AN' 10<br>PRAYERS |   |                   |                   |    |    |     |   |    |     |      |                   | ✓<br>10/45 |       |
| 158              | 44-42381<br>MISS ELISE               |   |                   |                   |    |    |     |   |    |     |      |                   | ✓<br>10/45 |       |
| 159              | 44-42397<br>(NONE)                   |   |                   |                   |    |    |     |   |    |     |      |                   | ✓<br>10/45 |       |
| 160              | 44-42412<br>FREE FOR ALL!!!          |   |                   |                   |    |    |     |   |    |     |      |                   | ✓<br>10/45 |       |
| 161              | 44-42467<br>(NONE)                   |   |                   |                   |    |    |     |   |    |     |      |                   | ✓<br>10/45 |       |
| 162              | 44-42487<br>(NONE)                   |   |                   | ✓<br>05/22/<br>45 |    |    |     |   |    |     |      |                   |            |       |
| TOTALS THIS PAGE |                                      |   | 2                 | 1                 |    |    |     |   |    |     |      | 2                 | 6          | 11    |
| BROUGHT FORWARD  |                                      |   |                   | 1                 |    |    |     |   | 1  |     |      |                   | 10         | 12    |
| TOTALS, OVERALL  |                                      |   | 2                 | 2                 |    |    |     |   | 1  |     |      | 2                 | 16         | 23    |

*Legend:*

|      |  |
|------|--|
| R    | Destruction As Result of Enemy Air Raid  |
| C    | Loss of Aircraft in Enemy Territory Due Directly to Enemy Action                                     |
| CA   | Accident and/or Salvage As Result of Enemy Combat Damage (In Friendly Territory)                     |
| MA   | Loss While on Mission While in Enemy Territory but Direct Enemy Action Not Involved                  |
| A    | Accident in Friendly Territory Causing Complete Destruction of Aircraft – Not Combat Mission Related |
| AM   | Same as A but Involved in Combat Mission   |
| AS   | Accident in Friendly Territory Resulting in Salvage of the Aircraft – Not Combat Mission Related     |
| ASM  | Same as AS but Involved in Combat Mission  |
| WWS  | Salvage of Aircraft as War Weary   |
| RAAF | Transfer of Aircraft to Royal Australian Air Force   |
| OG   | Transfer of Aircraft to Other Groups   |
| RUS  | Returned to U.S. at End of War   |



## TYPE 11 – FORD B-24 M-FO

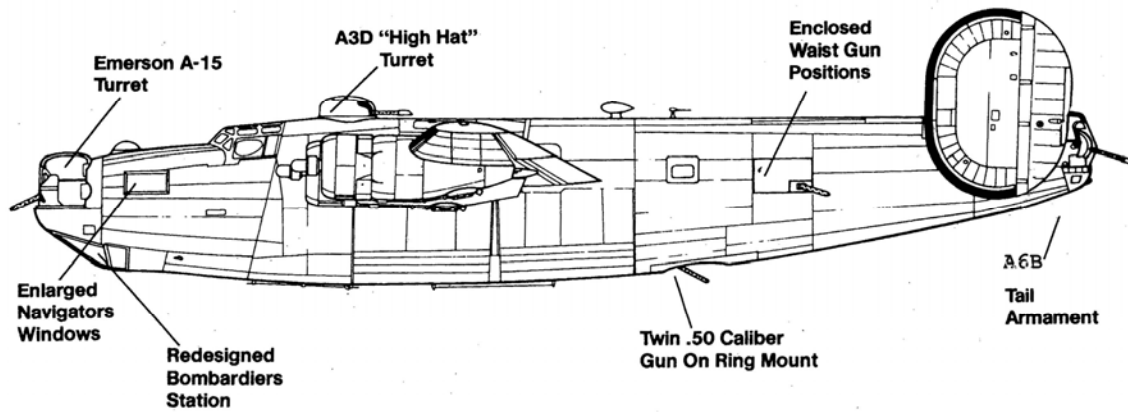

**NOTE NAVIGATOR'S DRIFT METER BEHIND COPILOT'S POSITION  
(RIGHT SIDE OF FORD M MODELS) IN FOLLOWING PICTURES.**



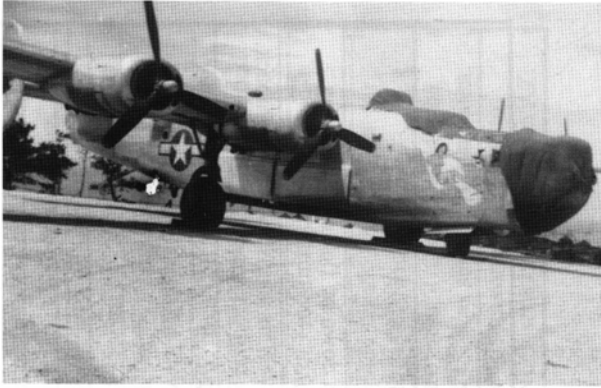

Source: Horton, *Best in the Southwest*, p. 462.

A 531st "M" carrying the last style of tail markings.  
*Robert Withom Collection*



This "M" has artwork that says "Flying Circus" on the suit case. *Clarence Frankford Collection*



Known to be with the 531st. *Frank Wojnilko Collection*

**STATISTICAL SUMMARY  
FATES OF OUR AIRCRAFT – PHILIPPINES CAMPAIGN  
380<sup>TH</sup> BOMB GROUP (H)**

**M-FO MODELS**

| #                | AIRCRAFT                       | R | C            | CA | MA | AM | ASM | A           | AS | WWS        | RAAF | OG | RUS        | TOTAL |
|------------------|--------------------------------|---|--------------|----|----|----|-----|-------------|----|------------|------|----|------------|-------|
| 167              | 44-50390<br>BECOMIN' BACK      |   | ✓<br>7/12/45 |    |    |    |     |             |    |            |      |    |            |       |
| 168              | 44-50396<br>POM POM EXPRESS    |   |              |    |    |    |     |             |    |            |      |    | ✓<br>10/45 |       |
| 169              | 44-50405<br>TEN HIGH           |   |              |    |    |    |     |             |    | ✓<br>02/46 |      |    |            |       |
| 170              | 44-50456<br>(NONE)             |   |              |    |    |    |     |             |    |            |      |    | ✓<br>10/45 |       |
| 171              | 4-50459<br>(NONE)              |   |              |    |    |    |     | ✓<br>9/8/45 |    |            |      |    |            |       |
| 172              | 44-50602<br>DOUBLE TROUBLE     |   |              |    |    |    |     |             |    |            |      |    | ✓<br>10/45 |       |
| 173              | 44-50776<br>THE RAMBLIN' WRECK |   |              |    |    |    |     |             |    |            |      |    | ✓<br>10/45 |       |
| 174              | 44-50782<br>(NONE)             |   |              |    |    |    |     |             |    |            |      |    | ✓<br>11/45 |       |
| 175              | 44-50794<br>(NONE)             |   |              |    |    |    |     |             |    |            |      |    | ✓<br>10/45 |       |
| 176              | 44-50811<br>PEACE OFFERING     |   |              |    |    |    |     |             |    |            |      |    | ✓<br>10/45 |       |
| 177              | 44-50894<br>LIBERTY BELLE      |   |              |    |    |    |     |             |    | ✓<br>12/45 |      |    |            |       |
| 178              | 44-50913<br>NOBODY'S DARLING   |   |              |    |    |    |     |             |    | ✓<br>10/46 |      |    |            |       |
| TOTALS THIS PAGE |                                |   | 1            |    |    |    |     | 1           |    | 3          |      |    | 7          | 12    |
| BROUGHT FORWARD  |                                |   |              |    |    |    |     |             |    |            |      |    |            |       |
| TOTALS, OVERALL  |                                |   | 1            |    |    |    |     | 1           |    | 3          |      |    | 7          | 12    |

**STATISTICAL SUMMARY  
FATES OF OUR AIRCRAFT – PHILIPPINES CAMPAIGN  
380<sup>TH</sup> BOMB GROUP (H)**

**M-FO MODELS (continued)**

| #                | AIRCRAFT                            | R | C | CA | MA | AM           | ASM          | A | AS | WWS        | RAAF | OG | RUS        | TOTAL |
|------------------|-------------------------------------|---|---|----|----|--------------|--------------|---|----|------------|------|----|------------|-------|
| 179              | 44-50927<br>(NONE)                  |   |   |    |    |              |              |   |    |            |      |    | ✓<br>10/45 |       |
| 180              | 44-50941<br>"VIRGIN ABROAD"         |   |   |    |    |              |              |   |    | ✓<br>10/45 |      |    |            |       |
| 181              | 44-50971<br>(NONE)                  |   |   |    |    |              | ✓<br>6/17/45 |   |    |            |      |    |            |       |
| 182              | 44-50977<br>(NONE)                  |   |   |    |    | ✓<br>6/21/45 |              |   |    |            |      |    |            |       |
| 183              | 44-50988<br>(NONE)                  |   |   |    |    |              |              |   |    |            |      |    | ✓<br>10/45 |       |
| 184              | 44-50997<br>(NONE)                  |   |   |    |    |              |              |   |    |            |      |    | ✓<br>10/45 |       |
| 185              | 44-50998<br>CLARINE FROM<br>ABILENE |   |   |    |    |              |              |   |    |            |      |    | ✓<br>10/45 |       |
| 186              | 44-51005<br>BACHELOR'S BROTHEL      |   |   |    |    |              |              |   |    |            |      |    | ✓<br>10/45 |       |
| 187              | 44-51100<br>(NONE)                  |   |   |    |    |              |              |   |    |            |      |    | ✓<br>10/45 |       |
| TOTALS THIS PAGE |                                     |   |   |    |    | 1            | 1            |   |    | 1          |      |    | 6          | 9     |
| BROUGHT FORWARD  |                                     |   | 1 |    |    |              |              | 1 |    | 3          |      |    | 7          | 12    |
| TOTALS, OVERALL  |                                     |   | 1 |    |    | 1            | 1            | 1 |    | 4          |      |    | 13         | 21    |

*Legend:*

|      |  |
|------|--|
| R    | Destruction As Result of Enemy Air Raid  |
| C    | Loss of Aircraft in Enemy Territory Due Directly to Enemy Action                                     |
| CA   | Accident and/or Salvage As Result of Enemy Combat Damage (In Friendly Territory)                     |
| MA   | Loss While on Mission While in Enemy Territory but Direct Enemy Action Not Involved                  |
| A    | Accident in Friendly Territory Causing Complete Destruction of Aircraft – Not Combat Mission Related |
| AM   | Same as A but Involved in Combat Mission   |
| AS   | Accident in Friendly Territory Resulting in Salvage of the Aircraft – Not Combat Mission Related     |
| ASM  | Same as AS but Involved in Combat Mission  |
| WWS  | Salvage of Aircraft as War Weary   |
| RAAF | Transfer of Aircraft to Royal Australian Air Force   |
| OG   | Transfer of Aircraft to Other Groups   |
| RUS  | Returned to U.S. at End of War   |

## **TYPE 12 – FORD B-24 M-FO**

### **B-24M-FO WITH REDESIGNED CANOPY/WINDSCREEN, OTHERWISE SIMILAR TO OTHER LATE MODEL FORD PRODUCTION**

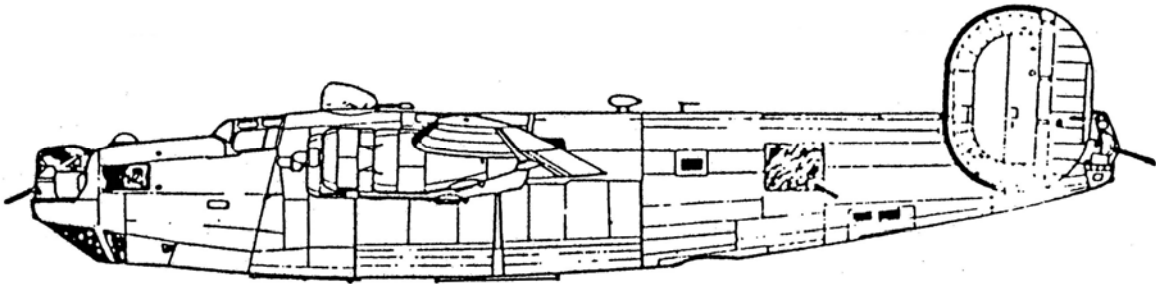

Willow Run made one last change to their B-24s with the introduction of the M-25-FO model; they made the front part of the canopy “V” shaped by taking out the flat center panel and the two triangular air vent windows. Aircraft with this modification had serials that began with 44-51252. Very few of these planes found their way into the 380<sup>th</sup>'s inventory. Compare the two pilot's enclosures on the following two pages taken from the B-24M Parts Manual.

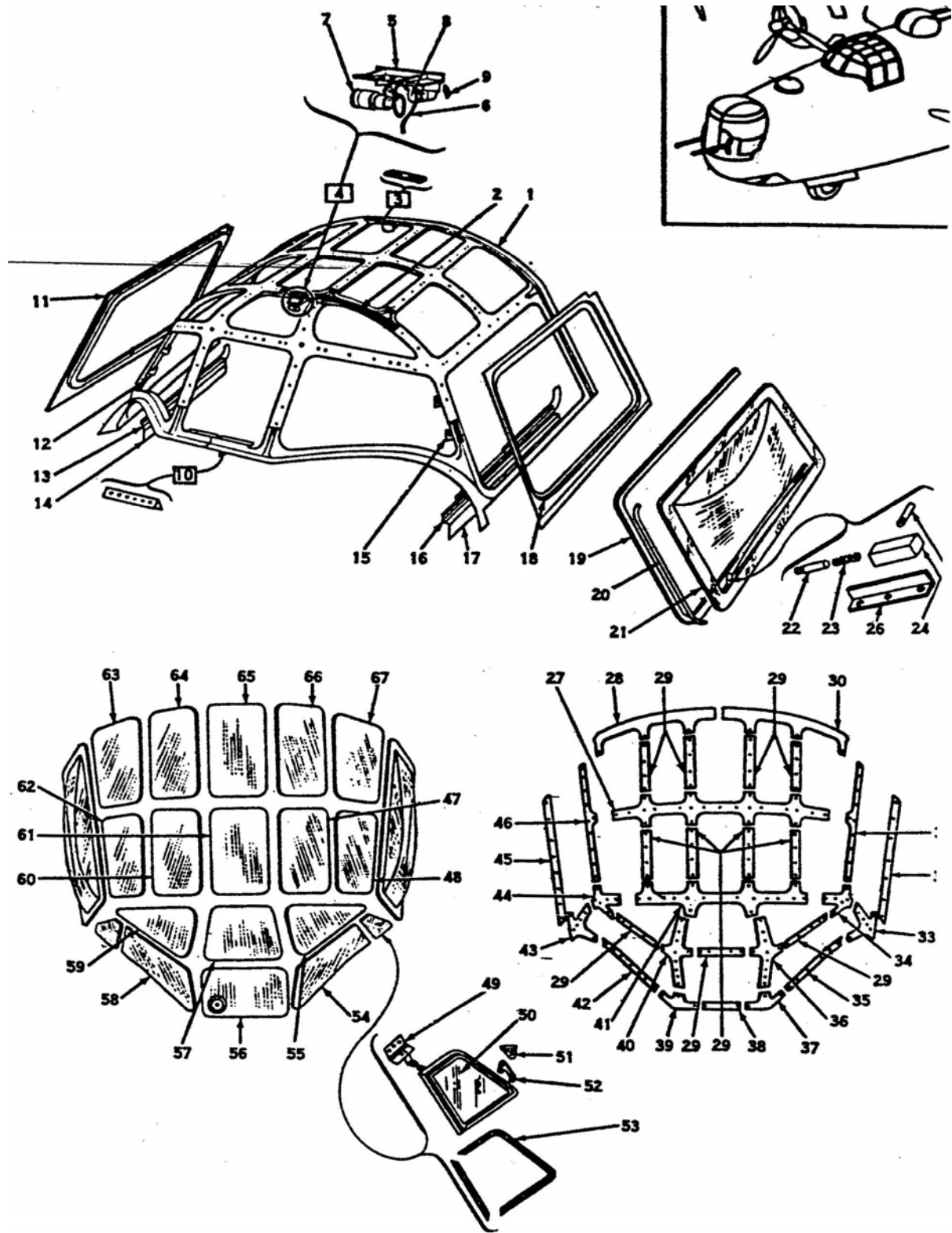

Source: Figure 10, B-24M Parts Manual.

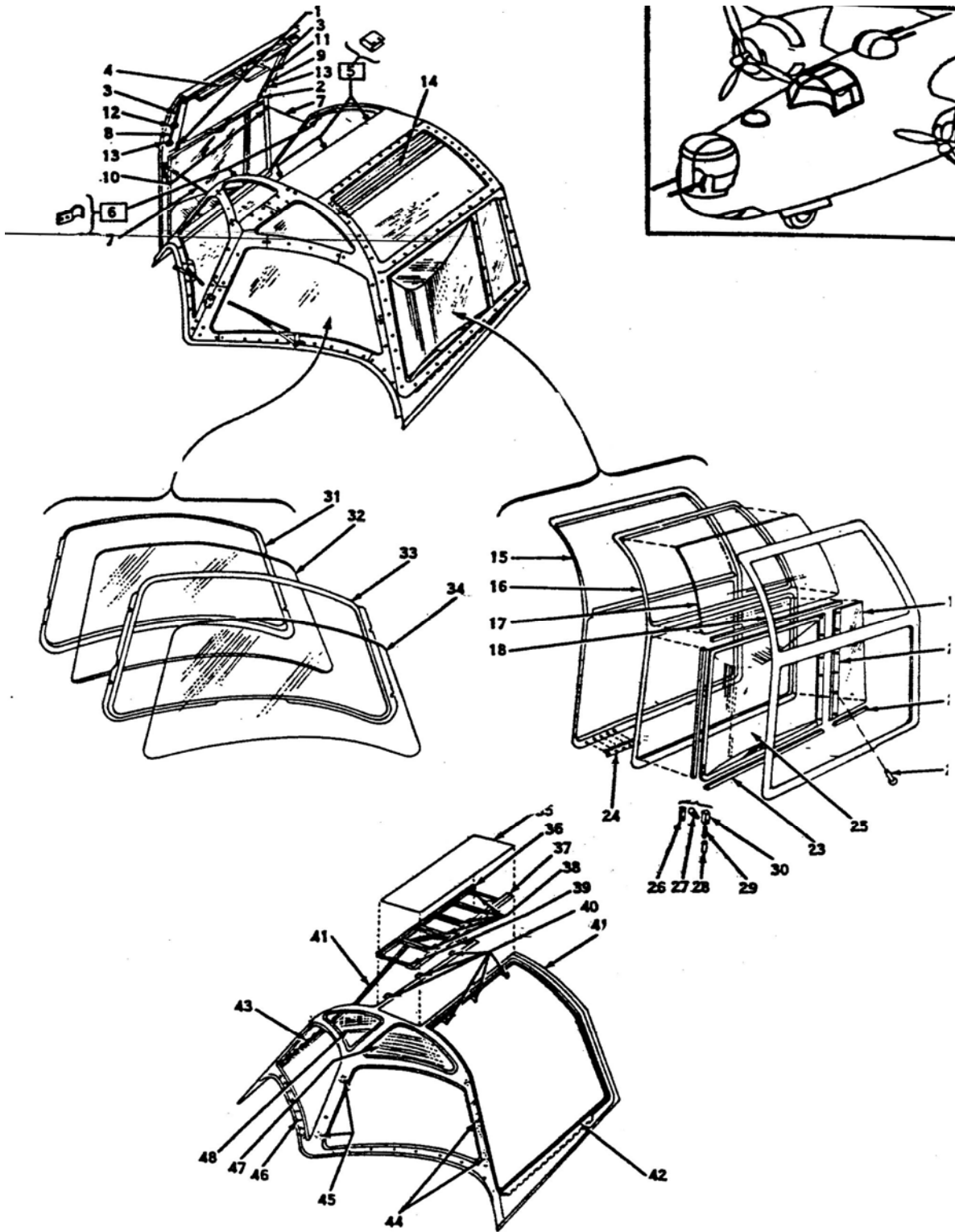

Source: Figure 11, B-24M Parts Manual.

**STATISTICAL SUMMARY  
FATES OF OUR AIRCRAFT – PHILIPPINES CAMPAIGN  
380<sup>TH</sup> BOMB GROUP (H)**

**M – FO – 25 ADV**

| #                | AIRCRAFT                     | R | C | CA | MA | AM | ASM | A | AS | WWS | RAAF | OG | RUS         | TOTAL |
|------------------|------------------------------|---|---|----|----|----|-----|---|----|-----|------|----|-------------|-------|
| 188              | 44-51264<br>(NONE)           |   |   |    |    |    |     |   |    |     |      |    | ✓<br>10/145 |       |
| 189              | 44-51301<br>STATE SIDE STUFF |   |   |    |    |    |     |   |    |     |      |    | ✓<br>10/145 |       |
| 190              | 44-51414<br>ATOMIC BLONDE    |   |   |    |    |    |     |   |    |     |      |    | ✓<br>10/145 |       |
| TOTALS THIS PAGE |                              |   |   |    |    |    |     |   |    |     |      |    | 3           | 3     |
| BROUGHT FORWARD  |                              |   |   |    |    |    |     |   |    |     |      |    |             |       |
| TOTALS, OVERALL  |                              |   |   |    |    |    |     |   |    |     |      |    | 3           | 3     |

*Legend:*

- R Destruction As Result of Enemy Air Raid
- C Loss of Aircraft in Enemy Territory Due Directly to Enemy Action
- CA Accident and/or Salvage As Result of Enemy Combat Damage (In Friendly Territory)
- MA Loss While on Mission While in Enemy Territory but Direct Enemy Action Not Involved
- A Accident in Friendly Territory Causing Complete Destruction of Aircraft – Not Combat Mission Related
- AM Same as A but Involved in Combat Mission
- AS Accident in Friendly Territory Resulting in Salvage of the Aircraft – Not Combat Mission Related
- ASM Same as AS but Involved in Combat Mission
- WWS Salvage of Aircraft as War Weary
- RAAF Transfer of Aircraft to Royal Australian Air Force
- OG Transfer of Aircraft to Other Groups
- RUS Returned to U.S. at End of War



**STATISTICAL SUMMARY  
FATES OF OUR AIRCRAFT – PHILIPPINES CAMPAIGN  
380<sup>TH</sup> BOMB GROUP (H)**

**AIRCRAFT WITHOUT A COMBAT HISTORY**

| #                | AIRCRAFT           | R | C | CA | MA | AM | ASM | A | AS | WWS        | RAAF | OG | RUS        | TOTAL |
|------------------|--------------------|---|---|----|----|----|-----|---|----|------------|------|----|------------|-------|
| 191              | 44-41874<br>(NONE) |   |   |    |    |    |     |   |    |            |      |    | ✓<br>10/45 |       |
| 192              | 44-42264<br>(NONE) |   |   |    |    |    |     |   |    |            |      |    | ✓<br>10/45 |       |
| 193              | 44-42314<br>(NONE) |   |   |    |    |    |     |   |    |            |      |    | ✓<br>10/45 |       |
| 194              | 44-42389<br>(NONE) |   |   |    |    |    |     |   |    |            |      |    | ✓<br>10/45 |       |
| 195              | 44-42416<br>(NONE) |   |   |    |    |    |     |   |    |            |      |    | ✓<br>10/45 |       |
| 196              | 44-42442<br>(NONE) |   |   |    |    |    |     |   |    | ✓<br>10/45 |      |    |            |       |
| 197              | 44-50458<br>(NONE) |   |   |    |    |    |     |   |    | ✓<br>09/45 |      |    |            |       |
| 198              | 44-51526<br>(NONE) |   |   |    |    |    |     |   |    |            |      |    | ✓<br>10/45 |       |
| 199              | 44-51872<br>(NONE) |   |   |    |    |    |     |   |    |            |      |    | ✓<br>10/45 |       |
| TOTALS THIS PAGE |                    |   |   |    |    |    |     |   |    | 2          |      |    | 7          | 9     |
| BROUGHT FORWARD  |                    |   |   |    |    |    |     |   |    |            |      |    |            |       |
| TOTALS, OVERALL  |                    |   |   |    |    |    |     |   |    | 2          |      |    | 7          | 9     |

*Legend:*

|      |  |
|------|--|
| R    | Destruction As Result of Enemy Air Raid  |
| C    | Loss of Aircraft in Enemy Territory Due Directly to Enemy Action                                     |
| CA   | Accident and/or Salvage As Result of Enemy Combat Damage (In Friendly Territory)                     |
| MA   | Loss While on Mission While in Enemy Territory but Direct Enemy Action Not Involved                  |
| A    | Accident in Friendly Territory Causing Complete Destruction of Aircraft – Not Combat Mission Related |
| AM   | Same as A but Involved in Combat Mission   |
| AS   | Accident in Friendly Territory Resulting in Salvage of the Aircraft – Not Combat Mission Related     |
| ASM  | Same as AS but Involved in Combat Mission  |
| WWS  | Salvage of Aircraft as War Weary   |
| RAAF | Transfer of Aircraft to Royal Australian Air Force   |
| OG   | Transfer of Aircraft to Other Groups   |
| RUS  | Returned to U.S. at End of War   |