

380TH BOMB GROUP

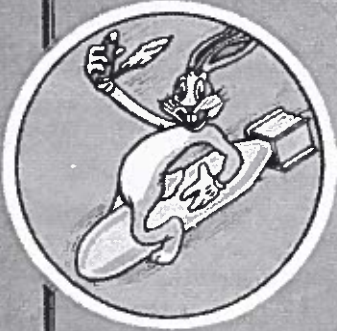

Flying Circus



HERKY-528, LIL BEAVER-629, BUGS BUNNY-530, DONALD DUCK-531 SQUADRONS

Francis [Signature]

Francis [Signature]

This Newsletter is Dedicated to:

*Forrest E. (Tommy) Thompson, Lt. Col. USAF (Ret.)
and
Helen H. Thompson*

*They had the foresight, perseverance, and love of the 380th
Bombardment Group (H) and its history, traditions, and person-
nel to organize, succor, and guide the*

380th Bombardment Group Association, Inc.

*our predecessor organization, for the past eighteen years
(1982-1999).*

Our everlasting thanks and love go out to them.

**THE 380TH BOMB GROUP ASSOCIATION
5th AF - RAAF**

AFFECTIONATELY KNOWN AS

The Flying Circus

208 CHIPPEWA ST.
WEST LAFAYETTE IN 47906-2123



NEWSLETTER #22

March 2005

Compatriots and Friends:

Looks like the San Diego Reunion is coming along just fine. The B-24 Model Dedication is now certain. It will be part of the Dedication of a Veterans Memorial in Balboa Park. This will be Friday, November 11th.

We will schedule our TAPS Memorial Service for Thursday, November 10th. Since there are no major Air Force Bases in the San Diego area, we will have to get the help of the Navy or Marines. Isabel and I are hoping for the Marines since our grandson Charlie is now in Iraq on his second tour with the First Battalion, 5th Marines.

We look forward to a great turnout. San Diego has many attractions, so come early if you can. See you all there.

To preserve the memory of the 380th.

Sincerely,



Theodore J. (Ted) Williams

HISTORIANS

Glenn R. Horton, Jr.
Gary L. Horton

HISTORIAN, AUSTRALIA

Bob Alford

EDITORS, HISTORY PROJECTS AND QUARTERLY NEWSLETTER

Barbara J. Gotham
Theodore J. (Ted) Williams

Phone: 765/494-7434
Fax: 765/494-2351
Email: tjwil@ecn.purdue.edu
[http://www.ecn.purdue.edu/
IIES/PLAIC/380/380.html](http://www.ecn.purdue.edu/IIES/PLAIC/380/380.html)

2005 REUNION INFORMATION

November 9-13, 2005
San Diego, California

Pat Carnevale has chosen the hotel for our Reunion. It is:

Holiday Inn San Diego Bayside
4875 North Harbor Drive
San Diego CA 92106

<http://www.holinnbayside.com/>

Rate of \$99 + 10.5% room tax for a total of \$109.40 per night
(single or double occupancy)

The hotel has a complimentary airport shuttle service, complimentary parking, and will give us a one-hour complimentary reception on Thursday evening. Our hospitality room is approximately 1400 sq ft, located on the top floor, with a view of the harbor. It looks like we'll have a very nice location for the 2005 reunion!

Here's some info on the hotel's location, from their website:

Located across from America's Cup Harbor and San Diego Bay, the Holiday Inn Bayside is conveniently close to all of San Diego's attractions. Magnificent parks, miles of sandy beaches and world-class shopping are all just minutes away. And, across the street you'll find sport fishing and whale watching tours.

San Diego International Airport	5 Minutes
Sea World	7 Minutes
San Diego Zoo	10 Minutes
San Diego Convention Center	5 Minutes
Gaslamp District	7 Minutes
Historic Old Town	10 Minutes
Golf	10 Minutes
Qualcomm Stadium	15 Minutes
Legoland	25 Minutes
Wild Animal Park	25 Minutes
Mexico	30 Minutes

San Diego is a great location for bringing your children and grandchildren. Lots to see and do for all ages!

RESEARCH FUND CONTRIBUTIONS

We'd like to thank the following members for their recent contributions to our research fund:

Ruth Bundy, in memory of Mrs. Wilfred Moran
Wil Moran, in memory of his wife
Robert Rhoden

2005 REUNION - SAN DIEGO - November 9-13, 2005

TENTATIVE REUNION SCHEDULE

WEDNESDAY, NOVEMBER 9

ALL DAY	REGISTRATION
AFTERNOON & EVENING	HOSPITALITY ROOM
EVENING	WELCOME BUFFET (HOTEL)

THURSDAY, NOVEMBER 10

MORNING	TAPS MEMORIAL SERVICE (SITE TO BE DETERMINED)
NOON	LUNCHEON
AFTERNOON	SAN DIEGO ZOO, BALBOA PARK
EVENING	HOSPITALITY ROOM

FRIDAY, NOVEMBER 11

10:00 AM	VETERANS DAY PARADE BALBOA PARK
12:00 PM	LUNCHEON
1:00 PM	DEDICATION OF VETS PARK AND B-24 MEMORIAL
AFTERNOON	VISIT AEROSPACE MUSEUM
6:00 PM	B-24 VETERANS DINNER AT AEROSPACE MUSEUM

SATURDAY, NOVEMBER 12

10:00 AM	MEMBERS MEETING
AFTERNOON	HOSPITALITY ROOM
6:00 PM	COCKTAILS
7:00 PM	DINNER/DANCE (HOTEL)

SUNDAY, NOVEMBER 13

DEPARTURE DAY

SAN DIEGO REUNION

HOTEL REGISTRATION FORM
Holiday Inn San Diego Bayside
4875 North Harbor Drive - San Diego, CA 92106
<http://www.holinnbayside.com/>

November 9 – 13, 2005

Name _____

Spouse or Guest _____

Address _____

City _____ State _____ Zip _____

Phone _____ e-mail _____

Rate: \$99 (single or double occupancy) + 10.5% room tax (Total \$109.36 per night)

Arrival Date _____

Departure Date _____

Room type: S = one person, one bed; D = two people, one bed; D/D = two people, two beds
(Circle Choice)

Special Needs: H=Handicap facilities; N/S = Non-smoking; S=Smoking; K=King bed
(Circle choice)

Guarantee by credit card # _____ exp date: _____

Signature _____

Name on card _____

Please print

Cancel policy for this event: 48 hours prior to arrival to avoid penalty

Please mail or fax reservation form to:

Carnevale & Associates, Inc.
P. O. Box 1230
Sonoita, AZ 85637
fax: 520- 455-5866
phone: 800-659-8808
e-mail: carne@dakotacom.net

As full service travel agents, we are also able to assist you with your travel arrangements including air and rental cars. **“ONE PHONE CALL DOES IT ALL”**
(800) 659-8808
.....

FUTURE REUNIONS

SURVEY RESULTS:

At our business meeting at the Reunion last fall, and as a survey in our December newsletter, we asked for input from our members regarding their choices for future reunion sites (from 2007 and beyond) -- here are the results:

San Diego, California	2005
New Orleans, Louisiana	2006
.....	
Colorado Springs, Colorado (AF Academy)	2007
Fort Walton Beach, Florida (Eglin AFB)	2008
Albuquerque, New Mexico (Kirtland AFB)	2009
Rapid City, South Dakota (Ellsworth AFB)	2010

THE 380TH IN THE PHILIPPINES CAMPAIGN - PART II

In the December 2004 issue of *THE FLYING CIRCUS*, Newsletter No. 21, we outlined the Philippines Campaigns of the Southwest Pacific Headquarters and noted briefly the place of the 380th Bomb Group in these. We promised to elaborate on this in the present issue.

As noted before, the first Operation, called GOSSIPMONGER, was to take place on the Talaud Islands with the invasion there scheduled for October 15, 1944, one month after the invasion of Morotai in the Halmaheras (Operation INTERLUDE). The next Operation (KING I) after ours was to be November 15, 1944, and attack Sarangani Peninsula (Davao Area) Mindanao. The 90th Bomb Group was to be sent there. The Leyte Invasion was then to follow on December 15.

However, as the world knows, these first two were cancelled because of the success of the Navy sweeps of August and September, and the Leyte Invasion was moved up to October 20, 1944.

Map I shows the relationships of Talaud to the Halmaheras and the Philippines. Map II shows planned airfields. We have added a set of tables to show where the 380th fits in this.

Exhibit I shows the Air Units and when they should arrive. Exhibit II, the Communications Channels involved. Exhibit III, overall air unit strength. Exhibit IV, shipping instructions for ground personnel, and Exhibit V, air field construction.

This would have been a violent period for the 380th, although the Second Landing on Mindanao proper would have already happened by the time we arrived at Talaud.

THE 380TH IN THE PHILIPPINES CAMPAIGN - PART II (cont.)

M A P I
TALAUD IN RELATION TO MINDANAO, PHILIPPINES
AND MOROTAI IN THE HALMAHERAS

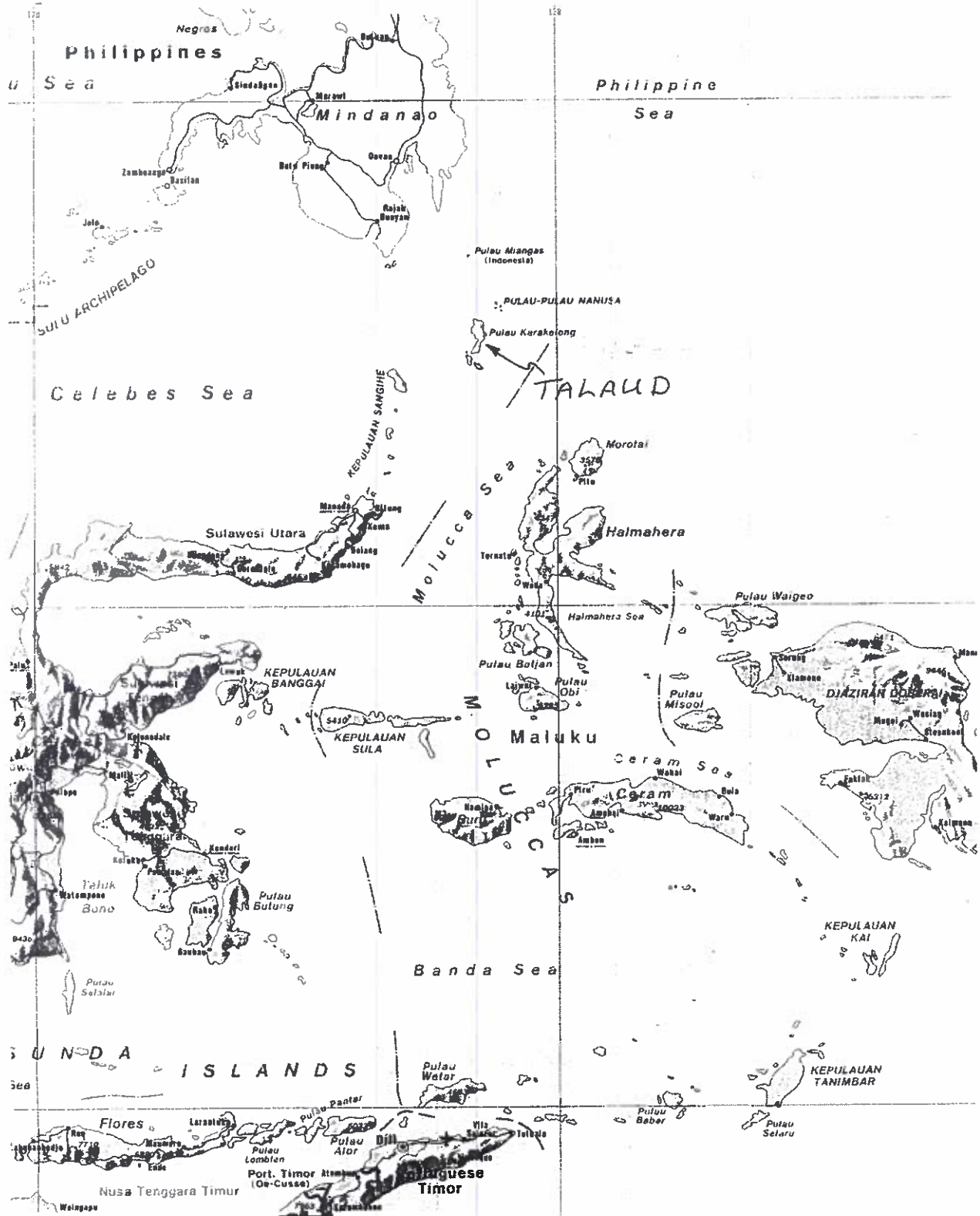

THE 380TH IN THE PHILIPPINES CAMPAIGN - PART II (cont.)

MAP II 380th AT WESTERN AIRFIELD TOP SECRET

22 July 1944

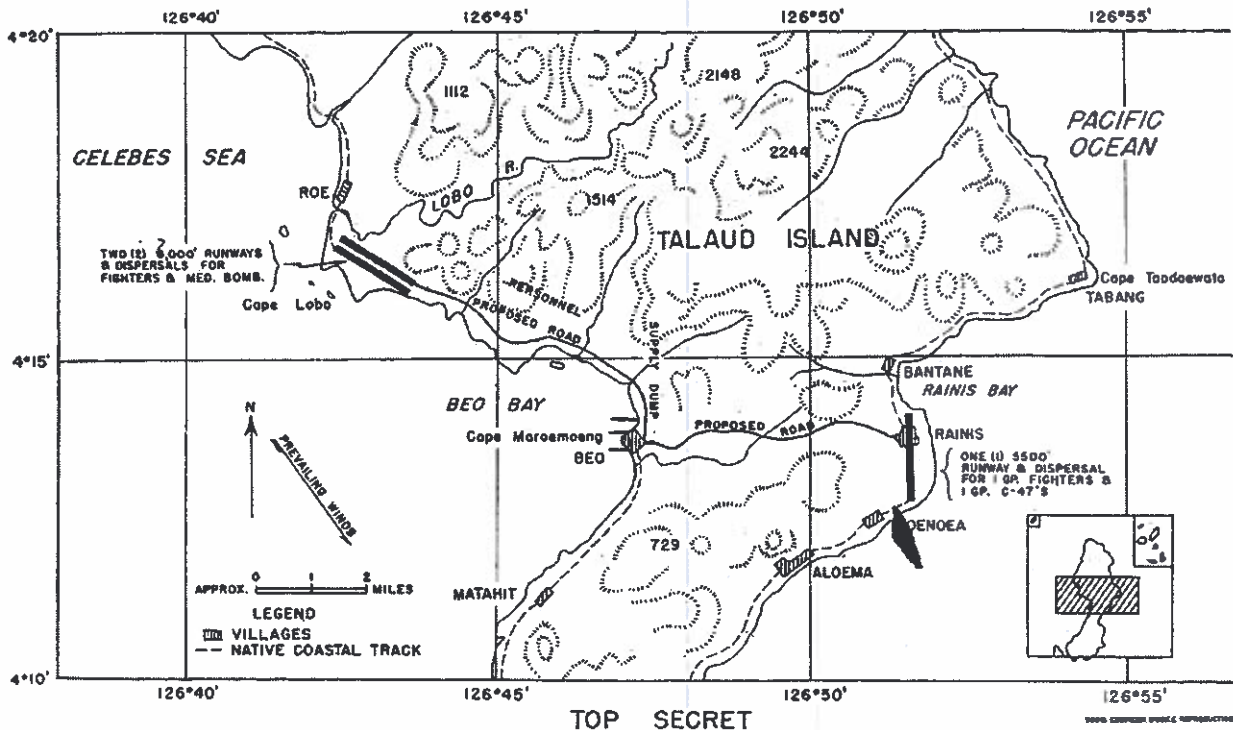

EXHIBIT I REVISED AIR GARRISON SCHEDULE

SECRET

ANALYSIS OF GARRISON LIST FOR GOSSIPMONGER

1. Revised garrison list dated 25 August.
2. Analysis of major service units
 - 1 Service Group Hq
 - 6 Service Squadrons
 - 3 Airdome Squadrons
 - 6 QM Trk Co's
 - 6 Ord S & M Co's
 - 2 QM Co's (SG)
 - 3 Sig Co's (SG)
 - 2(-) HP Co's
3. Analysis of major combat units
 - 1 Medium Bomber Group
 - 2 Fighter Groups
 - 1 Nite Fighter Squadron
 - 1 Photo Rcn Squadron
 - 2 Heavy Bomb Groups
 - 1 Emerg ASR Sq
4. Designation, location and requested arrival date of combat units:

D - 4	3 rd Emerg ASR Squadron (OA-10As)	HORLICKS (NOEMFOOR)
	345 th Bomber Group (B-25s)	HORLICKS
D - 7	421 st Nite Fighter Squadron (P-61s)	HORLICKS
	348 th Fighter Group (P-47s)	TABLETENNIS (SANSAPOR)
D - 9	26 th Photo Rcn Squadron (F-5)	HORLICKS
D - 11	475 th Fighter Group (P-38s)	HORLICKS
D - 25	380 th Bomber Group (B-24s)	THUNDERSTRUCK (DARWIN)
D - 45	22 nd Bomber Group (B-24s)	HORLICKS

THE 380TH IN THE PHILIPPINES CAMPAIGN - PART II (cont.)

EXHIBIT II COMMUNICATIONS CHANNELS FOR GOSSIPMONGER

SECRET

Principal Command & Liaison Channels

ANNEX 5A

Allied Air Forces Operations Instructions No. 65

28 August 1944

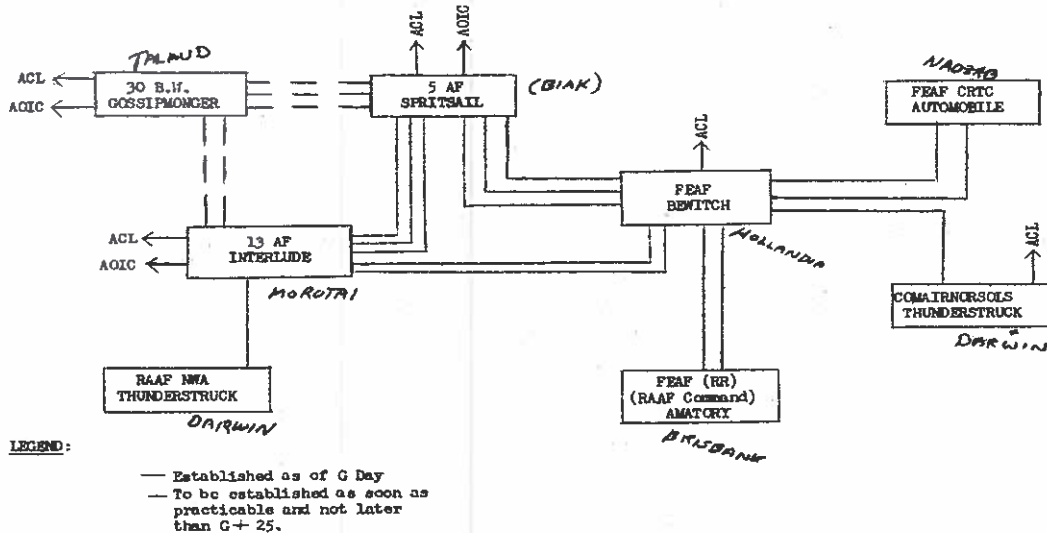

EXHIBIT III AIR UNIT STAFFING - GOSSIPMONGER (TALAUD)

SECRET

ANNEX 1 (TENTATIVE TROOP LIST)

TO

ALLIED AIR FORCES OPERATIONS INSTRUCTIONS No. 65

APO 925
SECRET
Auth Comdr
Init *W*
Date 28 August 1944.

INITIAL GARRISON LIST

<u>Unit</u>	<u>Approx. Personnel</u>
Adv Ech, 5th Air Force	300
X 308th Bomb Wing	235
X 348th Fighter Gp	1,080
X 475th Fighter Gp	1,089
X 421st MI Fl Sq	269
X 22d Bomb Gp	2,360
X 345th Bomb Gp	1,870
X 380th Bomb Gp	2,350
X 26th Photo Sq	130
320th Fl Contl Sq	437
2d Support Aircraft Party	15
7th Support Aircraft Party	15
Hq & Hq Sq, 63d Serv Gp	179
21st Serv Gp Opns Team #2	17
3d Airdrome Sq	237
78th Airdrome Sq	214
305th Airdrome Sq	210
30th Serv Sq	245
96th Serv Sq	226
389th Serv Sq	251
392d Serv Sq	145
479th Serv Sq	228
10th Serv Sq	245

THE 380TH IN THE PHILIPPINES CAMPAIGN - PART II (cont.)

**EXHIBIT IV
GROUND UNIT TRAVEL SCHEDULE**

TOP SECRET

Enclosure 2 - Schedule of Unit Movements - GOSSIPMONGER (cont'd)

<u>Date</u>	<u>Shipping Required</u>	<u>Unit</u>	<u>Pers</u>	<u>Veh</u>	<u>D/T Imped</u>	<u>Present Location</u>
411	6 ISF's	59. 474 Fighter Gp.	675	225	332	Horlicks
		60. 389 Service Sq.	254	69	266	Tablertennis
		61. 1018 Ord S & M Co.	84	26	37	Tablertennis
		62. 1134 Qd Co SG.	183	7	250	Automobile
		63. 1093 Signal Co. SG.	103	19	13	Bewitch
		64. 70 Airdrome Sq	214	40	94	Juvenile
425	1-Liberty	85. 30 Service Sq.	245	41	151	Thunderstruck
		86. 1010 Ord S & M Co	80	28	60	Thunderstruck
		87. 2725 Qd Trk Co	102	78	30	Thunderstruck
435	2-Liberties	88. 380 Bomb Gp	1361	265	727	Thunderstruck
438	1-Liberty	89. 479 Service Sq.	228	77	234	Automobile
		90. 1798 Ord S & M Co	80	25	40	Automobile
		91. 1039 Qd Trk Co	124	35	50	Automobile
445	1-Liberty	92. 22 Bomb Gp.	876	191	506	Horlicks

**EXHIBIT V
AIRFIELD CONSTRUCTION IN RELATION TO FOLLOWING OPERATIONS**

TOP SECRET

TALAUD (GOSSIPMONGER)

Airdrome Construction on TALAUD

G - Day - 15 Oct. 1944.

G - 15 - 1 - 5000'

G / 31 - 15 Nov. 1944. KING ONE

G / 30 - 1 - ~~5000'~~^{6000'}, 1 - 6000'

G / 53 - 7 Dec. 1944. KING THREE

G / 45 - 1 - ~~5000'~~^{6000'}, 1 - 7000'

G / 66 - 20 Dec. 1944. KING TWO

G / 60 - ~~5000'~~, 2 - 7000'

G / 108 - 31 Jan. 1945. LOVE TWO

NEXT OPERATIONS

G / 123 - 15 Feb. 1945. LOVE THREE

G / 128 - 20 Feb. 1945. MIKE ONE

G / 141 - 151 - 5-15 Mar. 1945. MIKE TWO

MY JOURNEY HOME

by John H. Miller
as told to Bill Bever

On January 22, 1945, John H. Miller, Technical Sergeant assigned to the 5th Air Force, 380th Bomb Group, 528th Squadron arrived at Mokeum Air Field on Biak Island. John had just completed his combat missions, flying aboard B-24 Liberators as a radio operator from air fields out of Fenton and Darwin, Australia.

The island of Biak, located off of the northern coast of West Papua (the Indonesian part of New Guinea) at the entrance to Geelvink Bay was the scene of a bloody battle won by General Mac Arthur and his 6th Army the previous May/June of 1944 after the Japanese had been rooted out. The US took over Biak Island's three air fields.

Many GIs arrived on Biak Island to get transportation back to the states after serving time in the Pacific. US bombers and air transports were flying back to the states so no one would be left behind. Within a few days John had two chances of flying back to the states on B-25s. The two B-25 bombers looked so beat up that John felt that because of their battle weary condition, they may not make the trip back to the states flying over the vast Pacific Ocean. This begun to work on John's mind so he decided to forego the plane ride, citing that his number might be up and he did not want to become shark bait.

John, wanting to get back to the States, decided on checking the ship docks for ships going back. Three weeks had passed when John went to the docks and discovered a Dutch Tropical Liner that was heading back to the States. The ship was looking for deck hands and since John was the lone member of his bomber crew left on the island, he decided to join on and become part of the ship's garbage detail. On the back of the ship contained a large holding hopper which held the ship's garbage. Every night, one hour after sundown, John pulled the lever on the hopper to drop the garbage to avoid detection by Japanese submarines and ships.

The Tropical Dutch Liner was used for inner island transportation of troops and supplies. This type of ship was not built for going across the Pacific. The ship's officers were a Dutch Captain and four Lieutenants. The crew consisted of fifteen American Navy seamen who manned the twin 40mm Bofor guns on the front and back of the ship. The cargo on board was approximately 150 American GIs with mental illnesses caused from the war. They were being transported back to the US for further medical evaluation and treatment. There were 10 ranking Non-Commissioned Officers on board to help with the patients. Part of the ship's crew were Huba-Huba boys (Hindu boys), who took food to the incarcerated GIs down below the deck along with other duties such as mopping the decks. John recalled that the Huba-Huba boys, when taking



a shower, showered with their clothes on. The smell from the Hindu boys and the vomit from down below convinced John to sleep topside the majority of his trip.

The Liner shoved off from shore heading out across the Pacific Ocean around the middle of February. After three days at sea, the ship in front of them radioed that their ship was receiving incoming torpedoes from a Japanese submarine. Luckily that ship was not hit, but convinced the Captain of the Dutch Liner to head on a Southern route to reduce the chances of being detected. Taking the Southern route resulted in prolonging John's total time at sea for 29 days. The Liner never made one stop on the entire trip back to the States.

From lack of diet, John lost 26 pounds. All food was rationed. As the Dutch Liner got near the coast of California, food became scarce. All the rest of the food was rationed. John was given a canteen of water with a spam sandwich each day until the spam run out. The last three days of their voyage, they were without ship food. John was able to buy some herring and crackers from the Huba-Huba boys for \$5.00. A mighty steep price for food, but it got John by until they got to California. As the ship finally docked after dark, they found out the dock was closed for the night. All they could do was look at the city lights and wait it out until day break. They had to go without anything to eat until food was delivered on board the following morning.

John was sent to Angel Island to get rid of his gear and on to his next duty station.

Even though John was at sea for 29 days and having to deal with all his hardships, it still gave him peace of mind knowing that if he had come back by plane from Biak Island it might have been his last flight never to see the California coast. Many times during W.W.II, intuition and divine intervention saved many American GI lives. At 83 years of age, John is still on his life journey whether he travels by land, sea or air.

**380TH BOMB GROUP ASSOCIATION
2005 MEMBERSHIP REGISTRATION FORM**

Date _____

Your Name _____

Squadron _____ 380th Duty _____

Please check if you are a * Regular Member _____ or an **Associate Member _____

**Associates: 380th Veteran's Name: _____

Relationship: _____ Sqdn: _____

Your Address _____

City _____ State _____ Zip _____

Phone _____ E-mail _____

Spouse's Name _____

* *Regular member* means an original member of the 380th Bomb Group.

** *Associate member* means a family member (or other affiliation) of an original member. If you are an Associate, please give the name of the original member, your relationship to that person, and his squadron number.

Annual payment of \$20 payable to **Carnevale & Associates** will help defray costs of mailings throughout the year. Please mail your registration form and check to:

**Carnevale & Associates
P.O. Box 1230
Sonoita AZ 85637**

Membership runs from Reunion to Reunion.

TAPS

*Day is done, gone the sun, from the lake from the hill
from the sky. All is well, safely rest, God is nigh.*

*Thanks and praise for our days 'neath the sun, 'neath
the stars, 'neath the sky. As we go, this we know
God is nigh.*



LEST WE FORGET



529th Borgstrom, Helen G., Wife of Carl Borgstrom, DOD 11/06/2004, Dousman, Wisconsin, reported by her husband

529th Carmichael, Charles C., Pilot, Carmichael's Crew (40), DOD 10/01/2001, Lompoc, California, reported by his son, John Carmichael

529th Hewett, George Wayne, Top Turret Gunner, Horton's Crew (34), DOD 02/2005, Edna, Kansas, reported by Glenn Horton, Jr.

529th Lee, Warren F., Ground Staff, DOD 08/10/1996, Clearwater, Florida, reported by his widow, Agnes

529th Silver, Edward, Navigator, Levandoski's Crew (43), DOD 10/01/2004, Boca Raton, Florida, reported by John Seckar

529th Wielar, Donald F., Flight Photographer, DOD 09/18/1988, Levittown, New York, reported by his son, Tom Wielar

530th Chelling, Edward H., Gunner, DeLoache's Crew (64), DOD 01/14/2005, Downey, California, reported by his daughter, Mary Sikes

530th Cutt, John, Armorer Gunner, Engen's Crew (76), DOD 12/06/2004, Clark, New Jersey, reported by Ralph Figueroa

530th Engen, Donal D., Aircraft Commander, Engen's Crew (76), DOD 12/30/2004, Thousand Oaks, California, reported by Ralph Figueroa

531st Richmann, Melvin R., Flight Engineer, Manley's Crew (84), DOD 07/08/1998, Iowa Falls, Iowa, reported by his nephew, Scott Richmann

Please send TAPS information to:
Theodore J. Williams, 208 Chippewa St.,
West Lafayette IN 47906-2123
Phone: 765/494-7434, 765/463-7828

